

Quick Reference Guide

This Quick Reference Guide will assist you in finding the information you're looking for.

GENERAL INFORMATION

HOW TO RIDE THE MOTORCYCLE

SAFE OPERATION

MAINTENANCE AND ADJUSTMENT

STORAGE

A Table of Contents is included after the Foreword.

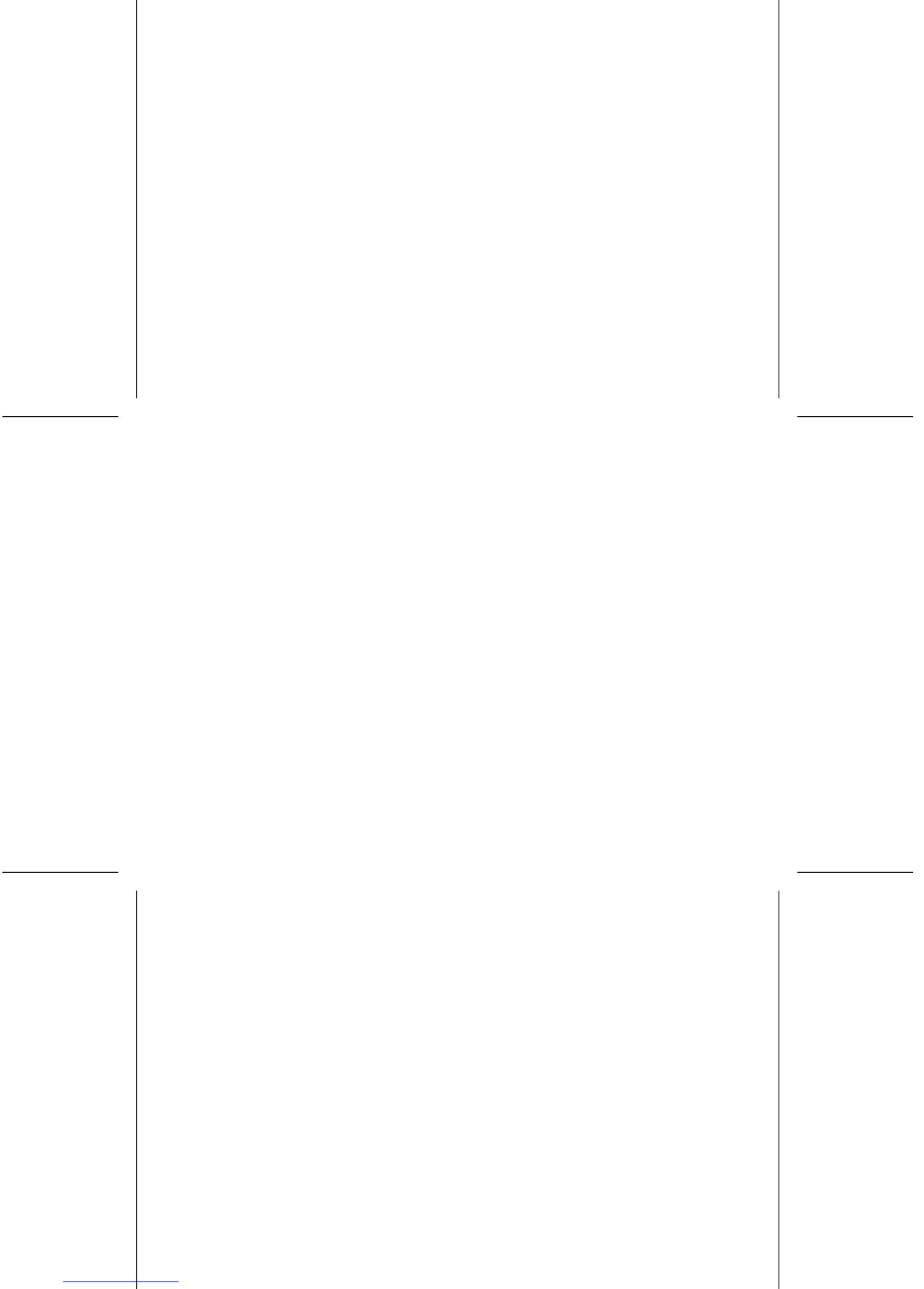

Whenever you see the symbols shown below, heed their instructions! Always follow safe operating and maintenance practices.

 **DANGER**

DANGER indicates a hazardous situation which, if not avoided, will result in death or serious injury.

 **WARNING**

WARNING indicates a hazardous situation which, if not avoided, could result in death or serious injury.

NOTICE

NOTICE is used to address practices not related to personal injury.

NOTE

○ *This note symbol indicates points of particular interest for more efficient and convenient operation.*

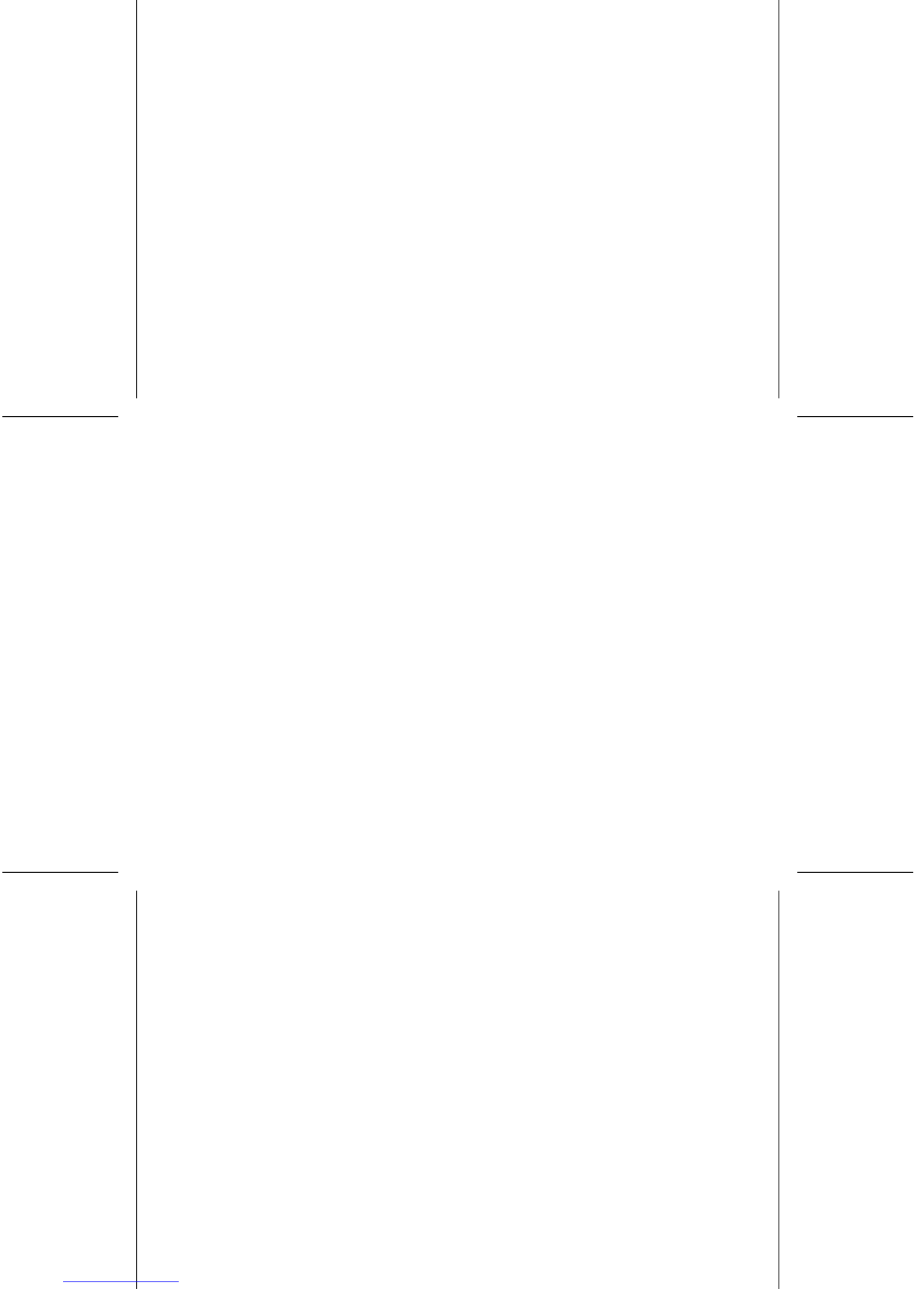

(Australian model only)

**TAMPERING WITH NOISE CONTROL SYSTEM
PROHIBITED**

Owners are warned that the law may prohibit:

- (a) The removal or rendering inoperative by any person other than for purposes of maintenance, repair or replacement, of any device or element of design incorporated into any new vehicle for the purpose of noise control prior to its sale or delivery to the ultimate purchaser or while it is in use; and
- (b) The use of the vehicle after such device or element of design has been removed or rendered inoperative by any person.

FOREWORD

Congratulations on your purchase of a new Kawasaki motorcycle. Your new motorcycle is the product of Kawasaki's advanced engineering, exhaustive testing, and continuous striving for superior reliability, safety and performance.

Please read this Owner's Manual carefully before riding so that you will be thoroughly familiar with the proper operation of your motorcycle's controls, its features, capabilities, and limitations. This manual offers many safe riding tips, but its purpose is not to provide instruction in all the techniques and skills required to ride a motorcycle safely. Kawasaki strongly recommends that all operators of this vehicle enroll in a motorcycle rider training program to attain awareness of the mental and physical requirements necessary for safe motorcycle operation.

To ensure a long, trouble-free life for your motorcycle, give it the proper care and maintenance described in this manual. For those who would like more detailed information on their Kawasaki Motorcycle, a Service Manual is available for purchase from any authorized Kawasaki motorcycle dealer. The Service Manual contains detailed disassembly and maintenance information. Those who plan to do their own work should, of course, be competent mechanics and possess the special tools described in the Service Manual.

Keep this Owner's Manual aboard your motorcycle at all times so that you can refer to it whenever you need information.

This manual should be considered a permanent part of the motorcycle and should remain with the motorcycle when it is sold.

All rights reserved. No part of this publication may be reproduced without our prior written permission.

This publication includes the latest information available at the time of printing. However, there may be minor differences between the actual product and illustrations and text in this manual.

All products are subject to change without prior notice or obligation.

KAWASAKI HEAVY INDUSTRIES, LTD.
Motorcycle & Engine Company

© 2011 Kawasaki Heavy Industries, Ltd.

Aug. 2011. (1)

TABLE OF CONTENTS

SPECIFICATIONS	10	Hazard Switch:	41
LOCATION OF PARTS	14	Brake/Clutch Lever Adjusters.....	41
LOADING AND ACCESSORIES		Fuel Tank Cap	42
INFORMATION	17	Fuel	43
GENERAL INFORMATION	20	Fuel Requirement:	43
Meter Instruments	20	Filling the Tank:.....	47
Tachometer	21	Stand.....	49
Multifunction Meter.....	22	Seats	50
Multifunction Display	24	Helmet Hooks.....	53
Warning/Indicator Lights:	33	Tool Kit	54
Keys	36	Tying Hooks	54
Ignition Switch/Steering Lock.....	36	Windshield.....	55
Right Handlebar Switches.....	38	BREAK-IN	56
Engine Stop Switch:	38	HOW TO RIDE THE MOTORCYCLE .	58
Starter Button:	39	Starting the Engine	58
Left Handlebar Switches	39	Jump Starting	60
Dimmer Switch:	39	Moving Off.....	63
Turn Signal Switch:.....	40	Shifting Gears	64
Horn Button:	40	Braking.....	65
Passing Button:	40		

Anti-lock Brake System (ABS) for models equipped with ABS.....	66	Valve Clearance.....	113
Yellow ABS Indicator Light.....	68	Air Cleaner.....	113
Stopping the Engine.....	69	Throttle Control System.....	115
Stopping the Motorcycle in an Emergency.....	70	Engine Vacuum Synchronization.....	118
Parking.....	71	Idle Speed.....	119
Catalytic Converter.....	73	Clutch.....	120
SAFE OPERATION	75	Drive Chain.....	123
Safe Riding Technique.....	75	Brakes.....	131
Daily Safety Checks.....	78	Brake Light Switches.....	136
Additional Considerations for High Speed Operation.....	81	Front Fork.....	138
MAINTENANCE AND ADJUSTMENT	83	Rear Shock Absorber.....	139
Periodic Maintenance Chart.....	84	Wheels.....	142
Engine Oil.....	96	Battery.....	147
Cooling System.....	102	Headlight Beam.....	152
Spark Plugs.....	110	Fuses.....	154
Evaporative Emission Control System (Southeast Asia B1 and Thailand models only).....	111	General Lubrication.....	156
Kawasaki Clean Air System.....	112	Cleaning Your Motorcycle.....	158
		STORAGE	164
		ENVIRONMENTAL PROTECTION	167
		OWNER SATISFACTION	168
		LOCATION OF LABELS	170

10 SPECIFICATIONS

SPECIFICATIONS

PERFORMANCE

Maximum Horsepower	53 kW (72.1 PS) @8 500 r/min (rpm)
(TH, SEA -B1/ B2)	52 kW (70.7 PS) @8 000 r/min (rpm)
(AU LAMS)	35 kW (47.6 PS) @8 000 r/min (rpm)
Maximum Torque	64 N·m (6.5 kgf·m, 47.2 ft·lb) @7 000 r/min (rpm)
(AU LAMS)	55 N·m (5.6 kgf·m, 40.6 ft·lb) @3 800 r/min (rpm)
Minimum Turning Radius	2.7 m (106.3 in.)

DIMENSIONS

Overall Length	2 110 mm (83.07 in.)
Overall Width	770 mm (30.31 in.)
Overall Height	1 180 mm (46.46 in.)
Wheelbase	1 410 mm (55.51 in.)
Road Clearance	130 mm (5.12 in.)
Curb Mass	(EX650E) 209 kg (461 lb)
(EX650E IN)	(EX650F) 211 kg (465 lb)

ENGINE

Type	DOHC, 4-valve, 2-cylinder, 4-stroke, liquid-cooled
Displacement	649 cm ³ (39.6 cu in.)
Bore × Stroke	83.0 × 60.0 mm (3.27 × 2.36 in.)
Compression Ratio	10.8 : 1
Starting System	Electric starter
Cylinder Numbering Method	Left to right, 1-2
Firing Order	1-2
Fuel System	FI (Fuel Injection)
Ignition System	Battery and coil (transistorized ignition)
Ignition Timing	10° BTDC @1 300 r/min (rpm) ~
(Electronically advanced)	37° BTDC @5 000 r/min (rpm)
Spark Plugs	NGK CR9EIA-9
Lubrication System	Forced lubrication (semi-dry sump)
Engine Oil	Type : API SG, SH, SJ, SL or SM with JASO MA, MA1 or MA2
	Viscosity: SAE 10W-40
	Capacity: 2.3 L (2.4 US qt)

12 SPECIFICATIONS

Coolant Capacity 1.2 L (1.3 US qt)

TRANSMISSION

Transmission Type 6-speed, return shift

Clutch Type Wet, multi disc

Driving System Chain drive

Primary Reduction Ratio 2.095 (88/42)

Final Reduction Ratio 3.067 (46/15)

Overall Drive Ratio 5.473 (Top gear)

Gear Ratio 1st 2.438 (39/16)

2nd 1.714 (36/21)

3rd 1.333 (32/24)

4th 1.111 (30/27)

5th 0.966 (28/29)

6th 0.852 (23/27)

FRAME

Castor 25°

SPECIFICATIONS 13

Trail		110 mm (4.3 in.)
Tire Size:	Front	120/70 ZR 17 M/C (58 W)
	Rear	160/60 ZR 17 M/C (69 W)
Rim Size:	Front	J17M/C × MT3.50
	Rear	J17M/C × MT4.50
Fuel Tank Capacity		16 L (4.2 US gal)

ELECTRICAL EQUIPMENT

Battery		12 V 10 Ah
Headlight		12 V 55 W/55 W (Hi/Lo)
Tail/Brake Light		LED

SEA-B1: Southeast Asia B1 model (with Evaporative Emission Control System)

SEA-B2: Southeast Asia B2 model

TH: Thailand model

IN: India model

AU LAMS: Australia Leaner Approved Motorcycle scheme model

Even if one of LED (Light Emitting Diode) tail/brake light does not go on, consult with an authorized Kawasaki dealer.

Specifications subject to change without notice, and may not apply to every country.

14 LOCATION OF PARTS

LOCATION OF PARTS

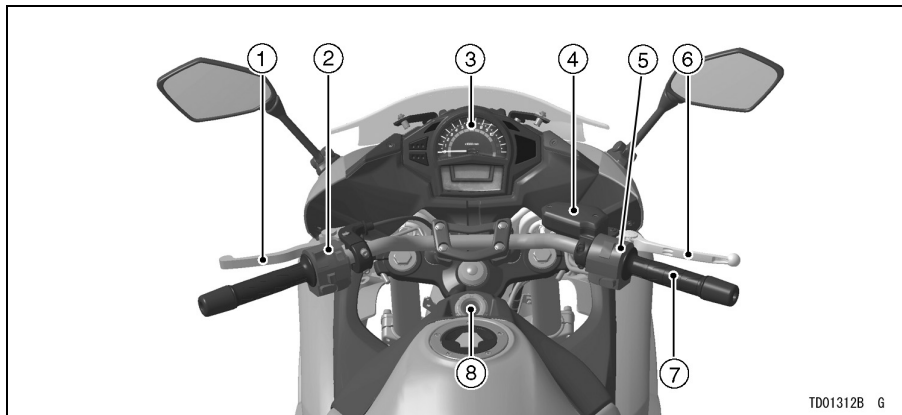

- 1. Clutch Lever
- 2. Left Handlebar Switches
- 3. Meter Instruments
- 4. Brake Fluid Reservoir (Front)

- 5. Right Handlebar Switches
- 6. Front Brake Lever
- 7. Throttle Grip
- 8. Ignition Switch/Steering Lock

LOCATION OF PARTS 15

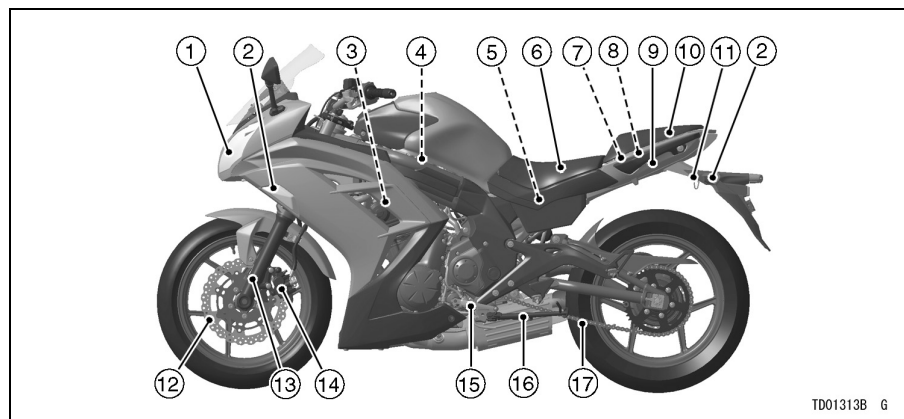

- 1. Headlight
- 2. Turn Signal Light
- 3. Spark Plugs
- 4. Air Cleaner
- 5. Battery
- 6. Rider's Seat

- 7. Helmet Holding Hooks
- 8. Tool Kit
- 9. Seat Lock
- 10. Passenger's Seat
- 11. Tying Hooks

- 12. Brake Disc
- 13. Front Fork
- 14. Brake Caliper
- 15. Shift Pedal
- 16. Side Stand
- 17. Drive Chain

16 LOCATION OF PARTS

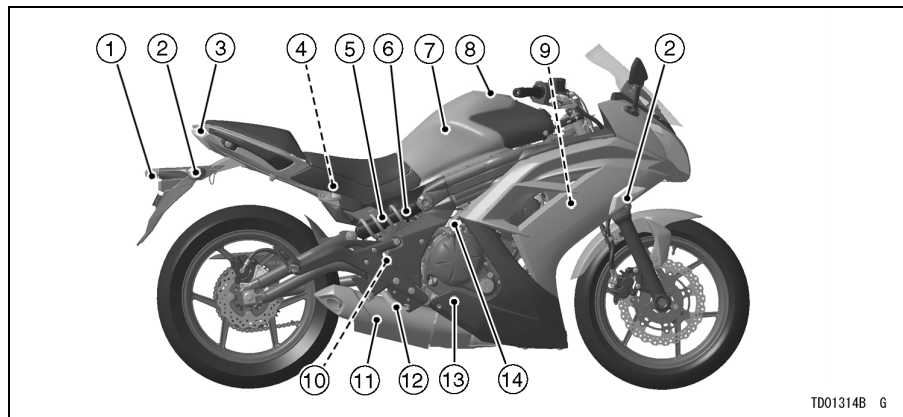

- | | |
|---------------------------------|---------------------------------|
| 1. License Plate Light | 8. Fuel Tank Cap |
| 2. Turn Signal Light | 9. Coolant Reserve Tank |
| 3. Tail/Brake Light | 10. Rear Brake Light Switch |
| 4. Brake Fluid Reservoir (Rear) | 11. Muffler |
| 5. Rear Shock Absorber | 12. Rear Brake Pedal |
| 6. Spring Preload Adjuster | 13. Oil Level Inspection Window |
| 7. Fuel Tank | 14. Idle Adjusting Screw |

LOADING AND ACCESSORIES INFORMATION

 WARNING

Incorrect loading, improper installation or use of accessories, or modification of your motorcycle may result in an unsafe riding condition. Before you ride the motorcycle, make sure it is not overloaded and that you have followed these instructions.

With the exception of genuine Kawasaki Parts and Accessories, Kawasaki has no control over the design or application of accessories. In some cases, improper installation or use of accessories, or motorcycle modification, will void the motorcycle warranty, can negatively affect performance, and can even be illegal.

In selecting and using accessories, and in loading the motorcycle, you are personally responsible for your own safety and the safety of other persons involved.

NOTE

○ *Kawasaki Parts and Accessories have been specially designed for use on Kawasaki motorcycles. We strongly recommend that all parts and accessories you add to your motorcycle be genuine Kawasaki components.*

Because a motorcycle is sensitive to changes in weight and aerodynamic forces, you must take extreme care in carrying cargo, passengers and/or in

18 LOADING AND ACCESSORIES INFORMATION

fitting additional accessories. The following general guidelines have been prepared to assist you in making your determinations.

1. Any passenger should be thoroughly familiar with motorcycle operation. The passenger can affect control of the motorcycle by improper positioning during cornering and sudden movements. It is important that the passenger sit still while the motorcycle is in motion and not interfere with the operation of the motorcycle. Do not carry animals on your motorcycle.
2. You should instruct any passenger before riding to keep his feet on the passenger footpegs and hold on to the operator or grab rail. Do not carry a passenger unless he or she is tall enough to reach the footpegs and footpegs are provided.
3. All baggage should be carried as low as possible to reduce the effect on the motorcycle center of gravity. Baggage weight should also be distributed equally on both sides of the motorcycle. Avoid carrying baggage that extends beyond the rear of the motorcycle.
4. Baggage should be securely attached. Make sure that the baggage will not move around while you are riding. Recheck baggage security as often as possible (not while the motorcycle is in motion) and adjust as necessary.
5. Do not carry heavy or bulky items on a luggage rack. They are designed for light items, and overloading can affect handling due to changes in weight distribution and aerodynamic forces.

LOADING AND ACCESSORIES INFORMATION 19

6. Do not install accessories or carry baggage that impairs the performance of the motorcycle. Make sure that you have not adversely affected any lighting components, road clearance, banking capability (i.e., lean angle), control operation, wheel travel, front fork movement, or any other aspect of the motorcycle's operation.
7. Weight attached to the handlebar or front fork will increase the mass of the steering assembly and can result in an unsafe riding condition.
8. Fairings, windshields, backrests, and other large items have the capability of adversely affecting stability and handling of the motorcycle, not only because of their weight, but also due to the aerodynamic forces acting on these surfaces while the motorcycle is in operation. Poorly designed or installed items can result in an unsafe riding condition.
9. This motorcycle is not intended to be equipped with a sidecar or to be used to tow any trailer or other vehicle. Kawasaki does not manufacture sidecars or trailers for motorcycles and cannot predict the effects of such accessories on handling or stability, but can only warn that the effects can be adverse and that Kawasaki cannot assume responsibility for the results of such unintended use of the motorcycle. Furthermore, any adverse effects on motorcycle components caused by the use of such accessories will not be remedied under warranty.

Maximum Load

Weight of rider, passenger, baggage, and accessories must not exceed 200 kg (441 lb).

Meter Instruments

- A. MODE Button
- B. Green Left Turn Signal Indicator Light
- C. Tachometer
- D. Red Zone
- E. Green Right Turn Signal Indicator Light
- F. Yellow ABS Indicator Light (Only on ABS model)
- G. Yellow Engine Warning Indicator Light
- H. Red Battery Charging System Warning Indicator Light
- I. RESET Button
- J. Multifunction Meter
- K. Green Neutral Indicator Light
- L. Blue High Beam Indicator Light
- M. Red Coolant Temperature Warning Indicator Light
- N. Red Oil Pressure Warning Indicator Light

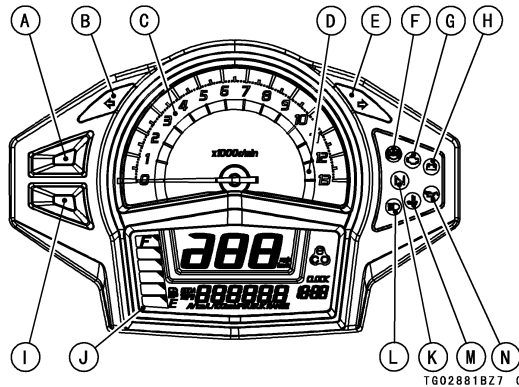

NOTE

○ *For safety, do not operate the instrument buttons while riding the motorcycle.*

Tachometer

The tachometer shows the engine speed in revolutions per minute (r/min, rpm). On the right side of the tachometer face is a portion called the “red zone”. Engine r/min (rpm) in the red zone is above maximum recommended engine speed and is also above the range for good performance.

NOTICE

Engine r/min (rpm) should not be allowed to enter the red zone; operation in the red zone will overstress the engine and may cause serious engine damage.

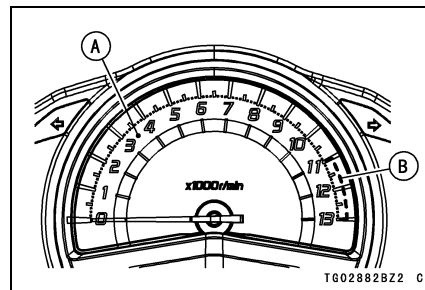

A. Tachometer
B. Red Zone

When the ignition key is turned to “ON”, the tachometer momentarily goes from the minimum to the maximum, then goes back from the maximum to the minimum reading to check its operation. If the tachometer does not operate correctly, have it checked by an authorized Kawasaki dealer.

22 GENERAL INFORMATION

Multifunction Meter

The multifunction meter displays the following functions.

- A. Fuel Gauge
- B. Speedometer
- C. Economical Riding Indicator
- D. Fuel Level Warning Symbol
- E. Multifunction Display
 - Odometer
 - Trip meter A
 - Trip meter B
 - Current Mileage
 - Average Mileage
 - Cruising Range
- F. Clock

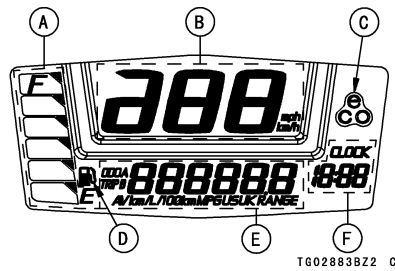

When the ignition key is turned to "ON", all LCD segments are displayed with opening display functions for few seconds, then the multifunction meter turns to operational mode.

Speedometer -

The speedometer shows the speed of the vehicle in digital values.

Unit Setting -

The unit setting in the meter instrument can be changed according to local regulations. Make sure the unit setting is correctly displayed before riding.

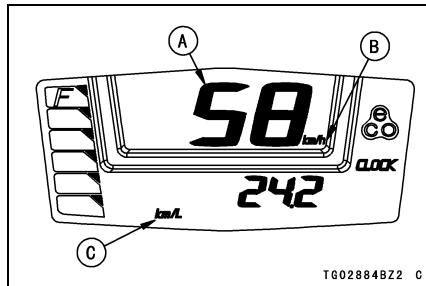

- A. Speedometer
- B. Speed Unit
- C. Mileage Unit

NOTE

- Do not operate the motorcycle with wrong unit (mph or km/h) of the speedometer.

To change the meter display units in the meter instrument as follows:

- Display the odometer in the multifunction display. Refer to the Multifunction Display section.
- Push the RESET button while pushing the MODE button to select the display units.

L/100km (km/h) → km/L (km/h) →
MPG US (mph) → MPG UK (mph) →
L/100km (km/h)...

- The display units on the multifunction meter can be changed depending on the selected mileage unit as shown.

24 GENERAL INFORMATION

Mileage Units	Speed Units	Distance Units
L/100km	km/h	km
km/L		
MPG US	mph	mile
MPG UK		

Multifunction Display

The following display modes can be shifted by pushing the MODE button.

Odometer → Trip meter A → Trip meter B → Current Mileage → Average Mileage → Cruising Range → Odometer...

NOTE

- *For safety, do not operate the instrument buttons while riding the motorcycle.*
- *The multifunction display is displayed in the unit depending on the unit mode setting, refer to the "Unit Setting" item in this section.*

Odometer -

The odometer shows the total distance in kilometers or miles that the vehicle has been ridden. This meter cannot be reset.

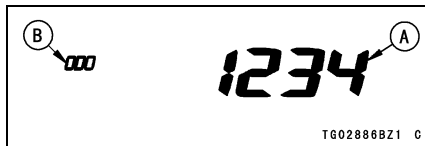

- A. Odometer
- B. "ODO"

NOTE

- *The data is maintained even if the battery is disconnected.*
- *When the figures come to 999999, they are stopped and locked.*

Trip Meter -

The trip meters show the distance in kilometers (miles) traveled since they were last reset to zero.

TRIP A: 0.0 ~ 9999.9
 TRIP B: 0.0 ~ 9999.9

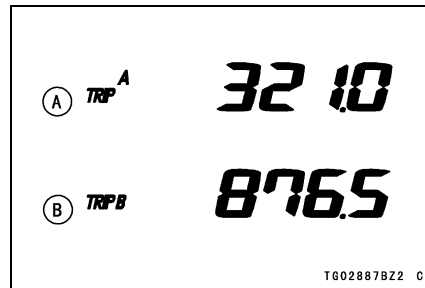

- A. Trip A
- B. Trip B

To reset the trip meter:

- Push the MODE button to display the trip meter A or B.

26 GENERAL INFORMATION

- Push the RESET button and hold it in.
- After two seconds, the figure display turns to 0.0, and then starts counting when the vehicle is operated. The meter counts until it is reset.

NOTE

- The data is maintained by the back-up power if the ignition key is turned off.
- When the trip meter reaches 9999.9 while running, the meters reset to 0.0 and continues counting.
- When the battery is disconnected, the meter display resets to 0.0.

Current Mileage -

This display mode shows the current mileage by numerical value. The current mileage display is renewed every 4 seconds.

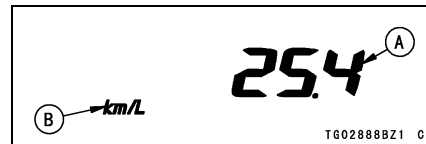

- A. Current Mileage
- B. "km/L"

NOTE

- The display unit modes can be changed, refer to the "Unit Setting" item in this section.
- The numerical value shows "--.--" until 4 seconds have passed and the speedometer is rises to above 5 km/h (3 mph).

Average Mileage -

This display mode shows the average mileage by numerical value counted from the start of measuring to present time. The average mileage display is renewed every 4 ~ 6 seconds.



- A. Average Mileage
- B. "AV km/L"

- While the average mileage is displayed, push the RESET button and hold it in until the average mileage values resets to "--. --".

NOTE

- *The display unit modes can be changed, refer to the "Unit Setting" item in this section.*
- *After resetting the average mileage, the numerical value is not displayed until 5 mL (0.2 US oz.) of fuel has been used and 100 m (328 ft) has been traveled.*
- *The data is maintained by back up power if the ignition switch is turned "OFF".*
- *When the battery is disconnected, the data resets to "--. --".*

28 GENERAL INFORMATION

Cruising Range -

This display shows the cruising range by numerical value and indicates the cruising range from the remaining fuel in the fuel tank. This cruising range display is renewed every 20 seconds.



- A. Cruising Range
- B. "RANGE"

The cruising range value displays "- -" when the fuel warning symbol (🚛) blinks in the multifunction meter.

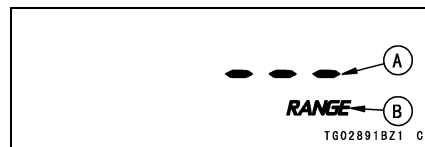

- A. "- -" display
- B. "RANGE"

NOTE

- The display unit modes can be changed, refer to the "Unit Setting" in this section.
- The display range for cruising range is 0 ~ 999.
- The cruising range value may not indicate the actual value. Use this value for your reference only.

Clock -

To adjust hours and minutes, do the followings while the motorcycle is at a stop.

- Turn the ignition switch to "ON".
- Display the odometer in the multi-function display. Refer to the "Multi-function Display" item in this section.
- Push the RESET button for more than 2 seconds. Both the hour and minute displays start blinking.

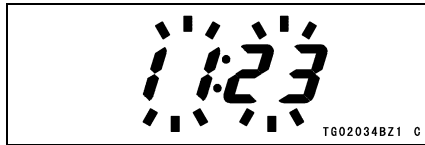

- Push the RESET button. The hour display only blinks. Push the MODE button to advance the hours.



- Push the RESET button. The hour display stops blinking and the minute display starts blinking. Push the MODE button to advance the minutes.

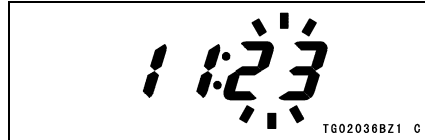

- Push the RESET button. Both the hour and minute displays start blinking again.

30 GENERAL INFORMATION

- Push the MODE button. The display stops blinking and the clock starts working.

NOTE

- Pushing the MODE button momentarily advances the hour or minute step by step. Pushing and holding the button advances the hour or minute continuously.
- The clock works normally by the back-up power while the ignition switch is turned "OFF".
- When the battery is disconnected, the clock is reset to 1:00 and starts working again when the battery is connected.

Economical Riding Indicator -

When the operator is driving the motorcycle for optimum fuel-efficiency, the

economical riding indicator appears on the multifunction meter to indicate favorable fuel consumption. Monitoring the economical riding indicator can help the rider maximize fuel efficiency.

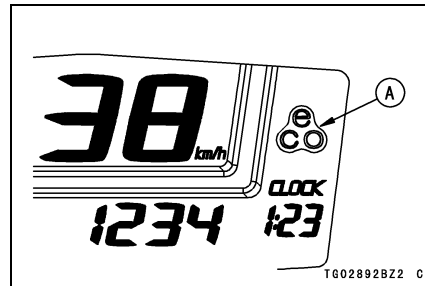

A. Economical Riding Indicator

⚠ WARNING

Failing to properly observe the road ahead increases the chance of an accident resulting in severe injury or death. Do not concentrate on the economical riding indicator by taking your eyes off the road; observe using peripheral vision.

Fuel Gauge –

The fuel in the fuel tank is shown by the number of segments displayed. When the fuel tank is full, all 6 segments are displayed.

If the fuel gauge is not correctly displayed, have the fuel gauge checked by an authorized Kawasaki dealer.

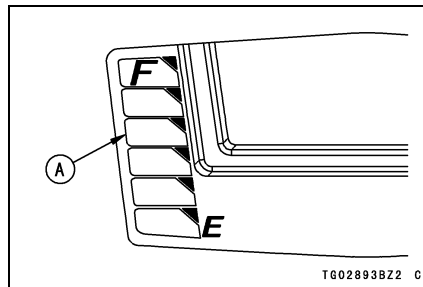

A. Fuel Gauge

32 GENERAL INFORMATION

As the fuel level in the tank goes down, the segments disappear one by one from F (full) to E (empty). When only the last 1 segment (E) is displayed in the fuel gauge, the fuel warning symbol (⛽) and the segment (E) are blinks.

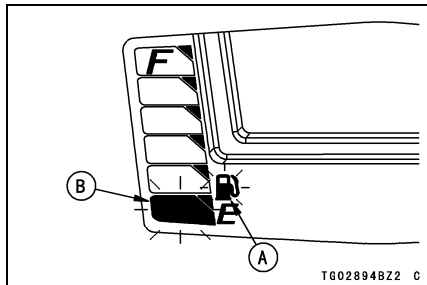

A. Fuel Warning Symbol (⛽)
B. Segment (E)

This indicates that the remaining fuel in the tank is approximately 4 L (1.1 US gal). Refuel at the earliest opportunity

if the fuel warning symbol (⛽) is displayed in the multifunction meter.

When vehicle stands with Side Stand, Fuel Gauge cannot show the amount of fuel in the fuel tank exactly. Stand upright the vehicle to check the fuel level.

All of the segments and fuel symbol will blink in case of the open or short of the wiring. Have the wiring inspected by an authorized Kawasaki dealer immediately.

NOTE

- When pushing the MODE button while low fuel warning is displayed, the multifunction display modes can be shifted.
- The cruising range value indicate the “— — —” when the low fuel warning is displayed.

Warning/Indicator Lights:

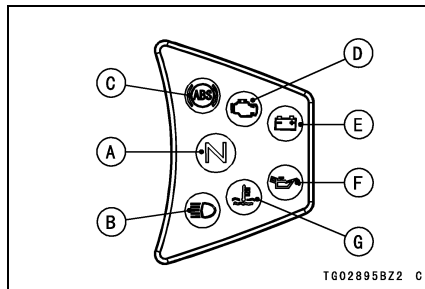

- A. Green Neutral Indicator Light
- B. Blue High Beam Indicator Light
- C. Yellow ABS Indicator Light (Only on ABS model)
- D. Yellow Engine Warning Indicator Light
- E. Red Battery Charging System Warning Indicator Light
- F. Red Oil Pressure Warning Indicator Light
- G. Red Coolant Temperature Warning Indicator Light

N: When the transmission is in neutral, the neutral indicator light goes on.

≡D: When the headlight is on high beam, the high beam indicator light goes on.

↔↔: When the turn signal switch is pushed to the left or right, the corresponding turn signal indicator light blinks.

34 GENERAL INFORMATION

Yellow ABS Indicator Light (For models equipped with ABS)

 : The ABS (Anti-lock Brake System) indicator light goes on when the ignition switch is turned on and goes off shortly after the motorcycle starts moving. If the ABS is normal, it stays off. If something is wrong with the ABS, the indicator goes on and stays on. When the indicator light is on, the ABS does not function but if the ABS fails, the conventional brake system will still work normally.

For more detailed information about ABS, see the Anti-lock Brake System (ABS) section in the How to Ride the Motorcycle chapter.

Yellow Engine Warning Indicator Light

 : The engine warning indicator light goes on when the ignition key is turned to "ON" and goes off soon after ensuring that its circuit functions properly. The indicator light also goes on or blinking whenever the troubles occur in digital fuel injection system (DFI).

The blinking of this indicator light indicates the condition that the engine cannot be started.

Refer to the Stopping the Engine section of the "How to Ride the Motorcycle" chapter for more information. If the indicator light goes on, have the DFI system checked by an authorized Kawasaki dealer.

Red Warning Indicator Lights

If any red warning indicator light goes on with the engine running, have

its cause checked by an authorized Kawasaki dealer.

 : This warning indicator light should go on whenever the ignition switch is turned to "ON" and go off after starting the engine.

The oil pressure warning indicator light goes on whenever the oil pressure is dangerously low while the engine running. Refer to the Maintenance and Adjustment chapter for more detailed engine oil information.

 : The coolant temperature warning indicator light goes on whenever the coolant temperature rises to 118°C (245°F) when the motorcycle is in operation. This warns the operator that the coolant temperature is too high. If the warning indicator light goes on, stop the engine and check the coolant

level in the reserve tank after the engine cools down.

NOTICE

Do not let the engine continue running when the warning indicator light goes on. Prolonged engine operation will result in severe damage from overheating.

 : The battery charging system warning indicator light goes on whenever the battery voltage is less than 11 V or higher than 16 V.

The warning indicator light and the battery warning indicator light still go on even after the battery is charged, ask an authorized Kawasaki dealer for an inspection.

36 GENERAL INFORMATION

Keys

This motorcycle has a combination key, which is used for the ignition switch/steering lock, seat lock, and fuel tank cap.

Blank keys are available at your Kawasaki dealers. Ask your dealer to make any additional spare keys you may need, using your original key as a master.

NOTICE

Be sure not to attach the key to a key chain that may damage the finish of the motorcycle.

Ignition Switch/Steering Lock

This is a four-position, key-operated switch. The key can be removed from the switch when it is in the OFF, LOCK, or P (Park) position.

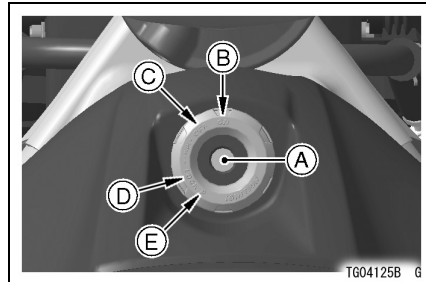

- A. Ignition Switch/Steering Lock
- B. ON position
- C. OFF position
- D. LOCK position
- E. P (Park) position

GENERAL INFORMATION 37

OFF	Engine off. All electrical circuits off.
ON	Engine on. All electrical equipment can be used.
LOCK	Steering locked. Engine off. All electrical circuits off.
P (Park)	Steering locked. Engine off. License plate, tail, and city lights on and turn signals can be used. All other electrical circuits cut off.

NOTE

- *The city, tail and license plate lights are on whenever the ignition key is in the ON position. One headlight goes on when the starter button is released after starting the engine. To avoid battery discharge, always start*

the engine immediately after turning the ignition key to "ON".

- *If you leave the P (Park) position on for a long time (one hour), the battery may become totally discharged.*

To operate the ignition Switch:

LOCK ← OFF ↔ ON



P (Park)

1. Turn the handlebar fully to the left.
2. For locking push down the key in the OFF position and turn it to LOCK.

TG04074B22 C

38 GENERAL INFORMATION

Right Handlebar Switches

Engine Stop Switch:

In addition to the ignition switch, the engine stop switch must be in the  position for the motorcycle to operate.

The engine stop switch is for emergency use. If required, move the engine stop switch to the  position.

NOTE

 Although the engine stop switch stops the engine, it does not turn off all the electrical circuits. Ordinarily, the ignition switch should be used to stop the engine.

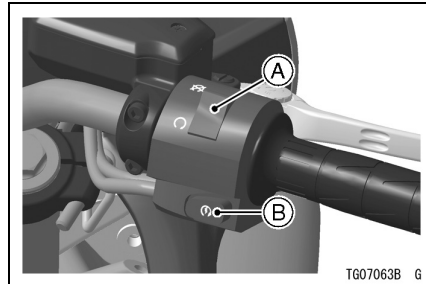

A. Engine Stop Switch
B. Starter Button

Starter Button:

The starter button operates the electric starter when the transmission is in neutral.

Refer to the Starting the Engine section of the "How to Ride the Motorcycle" chapter for starting instructions.

Left Handlebar Switches

Dimmer Switch:

High or low beam can be selected with the dimmer switch. When the headlight is on high beam (), the high beam indicator light is lit.

High beam.....()

Low beam.....()

40 GENERAL INFORMATION

NOTE

- *When the headlight is on high beam, both head lights go on. When the headlight is on low beam, only one headlight goes on.*

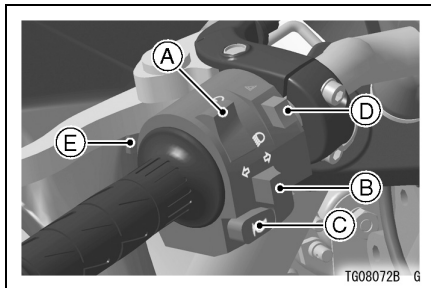

- A. Dimmer Switch
- B. Turn Signal Switch
- C. Horn Button
- D. Hazard Switch
- E. Passing Button

Turn Signal Switch:

When the turn signal switch is turned to the left (\leftarrow) or right (\rightarrow), the corresponding turn signal blinks on and off.

To stop blinking, push the switch in.

Horn Button:

When the horn button is pushed, the horn sounds.

Passing Button:

When the passing button is pushed, the headlight high beam (passing beam) goes on to signal the driver of the vehicle ahead that you are about to pass him. The passing light shuts off as soon as the button is released.

Hazard Switch:

If an emergency requires you to park on the highway shoulder, turn on the hazard lights to warn other drivers of your location.

Push in the hazard switch with the ignition switch in the ON or P (Park) position. All the turn signals and turn signal indicator lights will blink on and off.

NOTICE

If you leave the switch on for a long time, the battery may become totally discharged. So be careful not to use the hazard lights for more than 30 minutes.

Brake/Clutch Lever Adjusters

There is an adjuster on both the brake and clutch levers. Each adjuster has 5 positions so that the released lever position can be adjusted to suit the operator's hands. Push the lever forward and turn the adjuster to align the number with the mark on the lever holder.

The distance from the grip to the released lever is minimum at Number 5 and maximum at Number 1.

42 GENERAL INFORMATION

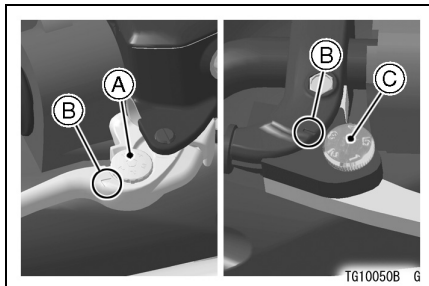

- A. Brake Lever Adjuster
- B. Mark
- C. Clutch Lever Adjuster

Fuel Tank Cap

To open the fuel tank cap, pull up the key hole cover. Insert the ignition key into the fuel tank cap and turn the key clockwise.

To close the cap, push it down into place with the key inserted. The key can be removed by turning it counterclockwise to the original position. Close the key hole cover.

NOTE

- *The fuel tank cap cannot be closed without the key inserted, and the key cannot be removed unless the cap is locked properly.*

NOTE

- Do not push on the key to close the cap, or the cap cannot be locked.

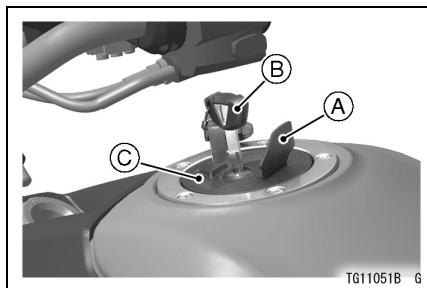

- A. Key Hole Cover
B. Ignition Key
C. Fuel Tank Cap

Fuel**Fuel Requirement:**

Your Kawasaki engine is designed to use only unleaded gasoline with a minimum octane rating shown below. Never use gasoline with an octane rating lower than the minimum specified by Kawasaki to prevent severe engine damage.

The octane rating of a gasoline is a measure of its resistance to detonation or "knocking". The term commonly used to describe a gasoline's octane rating is the Research Octane Number (RON).

44 GENERAL INFORMATION

NOTICE

Do not use leaded gasoline, as this will destroy the catalytic converter. (For further information, refer to the "Catalytic Converter" section in the "How to Ride the Motorcycle" chapter.)

NOTICE

If engine "knocking" or "pinging" occurs, use a different brand of gasoline of a higher octane rating. If this condition is allowed to continue, it can lead to severe engine damage. Gasoline quality is important. Fuels of low quality or not meeting standard industry specifications may result in unsatisfactory performance. Operating problems that result from the use of poor quality or no recommended fuel may not be covered under your warranty.

Fuel Type and Octane Rating

(Except for Australia, Brazil and Thailand Specifications)

Use clean, fresh unleaded gasoline with an octane rating equal to or higher than that shown in the table.

Fuel Type	Unleaded Gasoline
Minimum Octane Rating	Research Octane Number (RON) 91

NOTICE

Do not use any fuel with an ethanol in this vehicle. It has not been tested and certified for use with such fuels. Damage to the engine and fuel system, or engine starting and/or performance problems may result from the use of improper fuel.

(For Brazil Specification)

Use clean, fresh unleaded gasoline with an Antiknock Index equal to or higher than that shown in the table.

The Antiknock Index is posted on service station pumps. The Antiknock Index is an average of the Research Octane Number (RON) and the Motor Octane Number (MON) as shown in the table.

Fuel Type	Unleaded Gasoline
Ethanol Content	E25
Minimum Octane Rating	Antiknock Index $\frac{(RON + MON)}{2}$ 87

46 GENERAL INFORMATION

NOTICE

Do not use any fuel that contains more ethanol or other oxygenates than specified for E25 fuel* in this vehicle. Damage to the engine and fuel system, or engine starting and/or performance problems may result from the use of improper fuel.

*E25 means fuel containing up to 25% ethanol.

(For Australia and Thailand Specification)

Use clean, fresh unleaded gasoline with an ethanol volume content not more than 10 % and an octane rating equal to or higher than that shown in the table.

Fuel Type	Unleaded Gasoline
Ethanol Content	E10 or less
Minimum Octane Rating	Research Octane Number (RON) 91

NOTICE

Do not use any fuel that contains more ethanol or other oxygenates than specified for E10 fuel* in this vehicle. Damage to the engine and fuel system, or engine starting and/or performance problems may result from the use of improper fuel.

*E10 means fuel containing up to 10% ethanol.

Filling the Tank:

Avoid filling the tank in the rain or where heavy dust is blowing so that the fuel does not get contaminated.

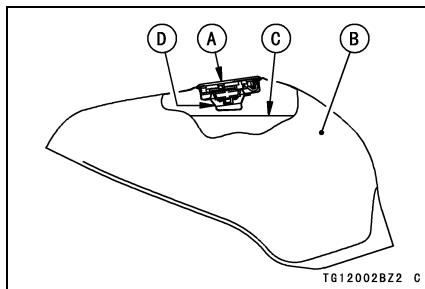

- A. Tank Cap
- B. Fuel Tank
- C. Top Level
- D. Filler Neck

⚠ WARNING

Gasoline is extremely flammable and can be explosive under certain conditions, creating the potential for serious burns. When refueling, servicing fuel system, draining gasoline and/or adjusting the carburetor: Stop engine and allow it to cool before refueling. DO NOT smoke. Make sure the area is well-ventilated and free from any source of flame or sparks, including the pilot light of any appliance. DO NOT fill the tank so the fuel level rises into the filler neck or level surface of level gauge. If the tank is over-filled, heat may cause the fuel to expand and overflow through the vents in the tank cap. Wipe off any spilled gasoline immediately.

48 GENERAL INFORMATION

NOTICE

Southeast Asia B1 and Thailand models only:
Never fill the tank so the fuel level rises into the filler neck. If the tank is overfilled, heat may cause the fuel to expand and flow into the Evaporative Emission Control System resulting in hard starting and engine hesitation and non compliance with the emission regulation.

NOTICE

Certain ingredients in gasoline may cause paint fading or damage. Be extra careful not to spill gasoline or gasoline oxygenates blends during refueling.

GENERAL INFORMATION 49

Stand

The motorcycle is equipped with a side stand.

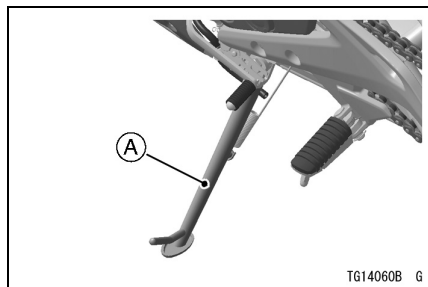

A. Side Stand

Do not sit on the motorcycle while it is on its side stand. Always kick the stand fully up before sitting on the motorcycle.

NOTE

- *The motorcycle is equipped with a side stand switch. This switch is designed so that the engine does not start if the transmission is in gear and the side stand is down.*

NOTE

- *When using the side stand, turn the handlebar to the left.*

50 GENERAL INFORMATION

Seats

Passenger's Seat Removal

- Insert the ignition key into the seat lock, and turn it clockwise.
- Remove the passenger's seat by pulling up the front of seat while turning the ignition key.

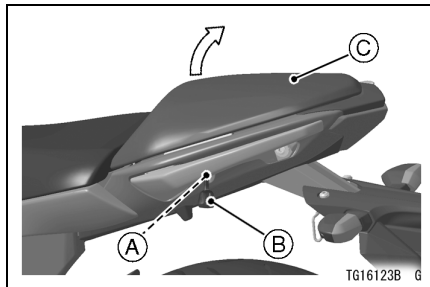

- A. Seat Lock
- B. Ignition Key
- C. Passenger's Seat

Rider's Seat Removal

- Remove the passenger's seat.
- Slide the rider's seat rearward then pull the front of seat upward to remove it.

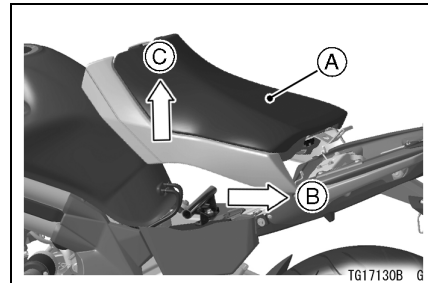

- A. Rider's Seat
- B. Slide Seat Rearward
- C. Pull Seat Upward

Rider's Seat Installation

- Slide the rider's seat rearward to position it on the frame.
- Slide the rider's seat forward to engage the tab under the seat with the bracket on the frame.

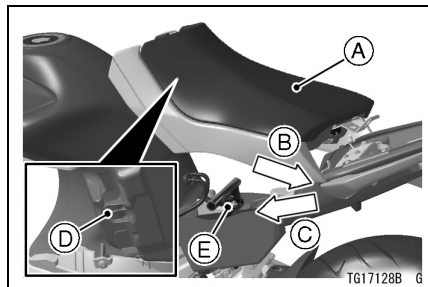

- A. Rider's Seat**
- B. Slide Seat Rearward**
- C. Slide Seat Forward**
- D. Tab**
- E. Bracket**

Passenger's Seat Installation

- Insert the tab under the passenger's seat into the hole in the frame.
- Insert the lock plate of the passenger's seat into the slot on the frame while aligning the projection with the hole on the frame.

52 GENERAL INFORMATION

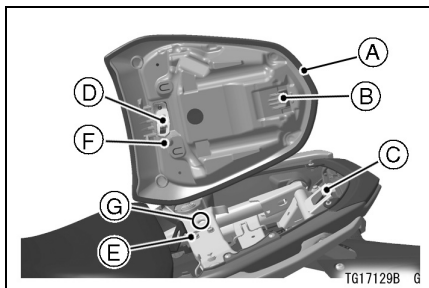

- A. Passenger's Seat
- B. Tab
- C. Hole
- D. Lock Plate
- E. Slot
- F. Projections
- G. Hole

- Push down the front part of the passenger's seat until the lock clicks.

- Pull up the front and rear ends of the passenger's seat to make sure they are securely locked.

Helmet Hooks

Helmets can be secured to the motorcycle by the helmet hooks located under the passenger's seat.

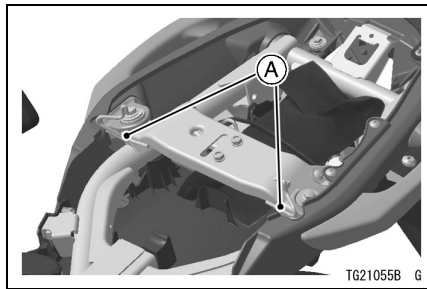

A. Helmet Hooks

WARNING

Riding with helmets attached to the hooks could cause an accident by distracting the operator or interfering with normal vehicle operation. Do not ride the motorcycle with helmets attached to the hooks.

54 GENERAL INFORMATION

Tool Kit

The tool kit is located under the passenger's seat.

The kit contains tools that are helpful in making roadside repairs, adjustments, and some maintenance procedures explained in this manual. Keep the tool kit in the original place.

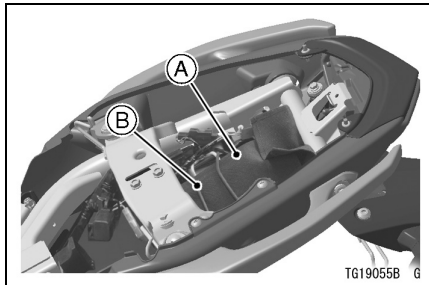

A. Tool Kit
B. Band

Tying Hooks

When tying up light loads to the passenger's seat, use the tying hooks located on the left and right sides of the rear fender.

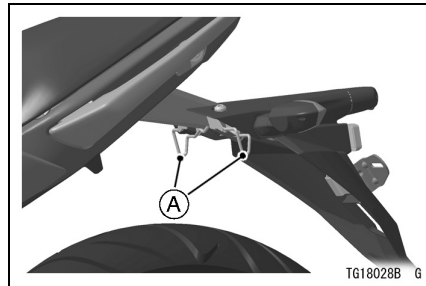

A. Tying Hooks

Windshield

The windshield can be adjusted within 3 positions in height to suit the rider's preference.

- Remove the four bolts and windshield.

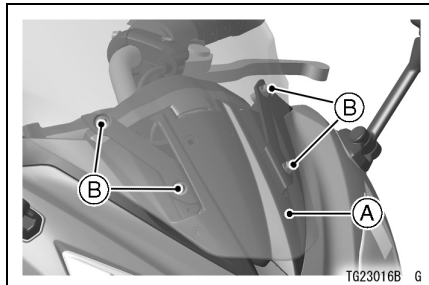

A. Windshield
B. Bolts and Nylon Washers

- Remove the windshield bracket mounting bolts.

- Reinstall the removed parts in the windshield positions to suit the rider's preference.

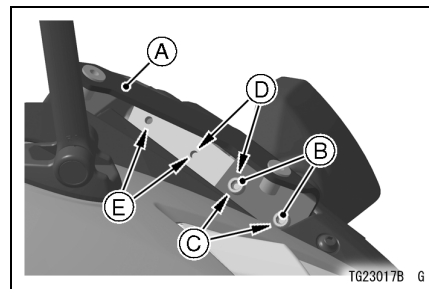

A. Windshield Bracket
B. Bolts
C. Low Position
D. Middle Position
E. High Position

BREAK-IN

The first 1 600 km (1 000 mi) that the motorcycle is ridden is designated as the break-in period. If the motorcycle is not used carefully during this period, you may very well end up with a “broken down” instead of a “broken in” motorcycle after a few thousand kilometers.

The following rules should be observed during the break-in period.

- The table shows maximum recommended engine speed during the break-in period.

Distance traveled	Maximum engine speed
0 ~ 800 km (0 ~ 500 mi)	4 000 r/min (rpm)
800 ~ 1 600 km (500 ~ 1 000 mi)	6 000 r/min (rpm)

NOTE

- *When operating on public roadways, keep maximum speed under traffic law limits.*
- Do not start moving or race the engine immediately after starting it, even if the engine is already warm. Run the engine for two or three minutes at idle speed to give the oil a chance to work up into all the engine parts.
- Do not race the engine while the transmission is in neutral.

 **WARNING**

New tires are slippery and may cause loss of control and injury. A break-in period of 160 km (100 miles) is necessary to establish normal tire traction. During break-in, avoid sudden and maximum braking and acceleration, and hard cornering.

In addition to the above, at 1 000 km (600 mi) it is extremely important that the owner have the initial maintenance service performed by an authorized Kawasaki dealer.

HOW TO RIDE THE MOTORCYCLE

Starting the Engine

- Check that the engine stop switch is in the  position.
- Turn the ignition key to "ON".
- Make sure the transmission is in neutral.
- Without holding the throttle grip, push the starter button to start the engine.

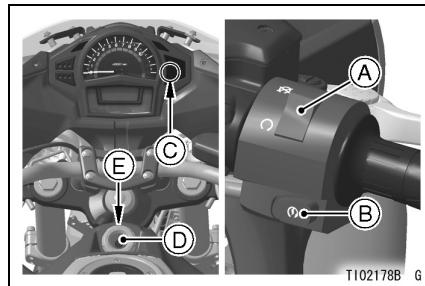

- A. Engine Stop Switch
- B. Starter Button
- C. Neutral Indicator Light
- D. Ignition Switch
- E. ON position

NOTE

- *The motorcycle is equipped with a vehicle-down sensor which causes the engine to stop automatically if the*

motorcycle falls down. The engine warning indicator light () blinks when the starter button pressed if the engine cannot be started. After righting the motorcycle, first turn the ignition key to "OFF" and then back to "ON" before starting the engine.

designed so that the engine does not start if the transmission is in gear and the side stand is down. However, the engine can be started if the clutch lever is pulled and the side stand is fully up.

NOTICE

Do not operate the starter continuously for more than 5 seconds, or the starter will overheat and the battery power will drop temporarily. Wait 15 seconds between each operation of the starter to let it cool and the battery power recover.

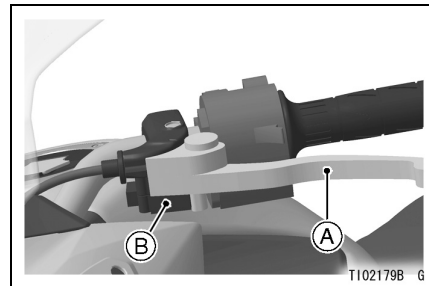

A. Clutch Lever
B. Starter Lockout Switch

NOTE

- The motorcycle is equipped with a starter lockout switch. This switch is

NOTICE

Do not let the engine idle longer than five minutes, or engine overheating and damage may occur.

Jump Starting

If your motorcycle battery is “run down,” it should be removed and charged. If this is not practical, a 12 volt booster battery and jumper cables may be used to start the engine.

⚠ DANGER

Battery acid generates hydrogen gas which is flammable and explosive under certain conditions. It is present within a battery at all times, even in a discharged condition. Keep all flames and sparks (cigarettes) away from the battery. Wear eye protection when working with a battery. In the event of battery acid contact with skin, eyes, or clothing, wash the affected areas immediately with water for at least five minutes. Seek medical attention.

Connecting Jumper Cables

- Remove the passenger's seat and rider's seat.
- Make sure the ignition key is turned to OFF.

- Connect a jumper cable from the positive (+) terminal of the booster battery to the positive (+) terminal of the motorcycle battery.

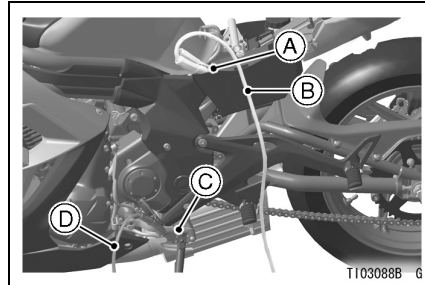

- A. Motorcycle Battery Positive (+) Terminal
- B. From Booster Battery Positive (+) Terminal
- C. Shift Pedal
- D. From Booster Battery Negative (-) Terminal

- Connect another jumper cable from the negative (-) terminal of the booster battery to shift pedal or other

62 HOW TO RIDE THE MOTORCYCLE

unpainted metal surface on your motorcycle. Do not use the negative (-) terminal of the battery.

⚠ DANGER

Batteries contain sulfuric acid that can cause burns and produce hydrogen gas which is highly explosive. Do not make this last connection at the fuel system or battery. Take care not to touch the positive and negative cables together, and do not lean over the battery when making this last connection. Do not connect to a frozen battery. It could explode. Do not reverse polarity by connecting positive (+) to negative (-), or a battery explosion and serious damage to the electrical system may occur.

- Follow the standard engine starting procedure.

NOTICE

Do not operate the starter continuously for more than 5 seconds or the starter will overheat and the battery power will drop temporarily. Wait 15 seconds between each operation of the starter to let it cool and the battery power recover.

- After the engine has started, disconnect the jumper cables. Disconnect the negative (-) cable from the motorcycle first.
- Reinstall the removed parts.

Moving Off

- Check that the side stand is up.
- Pull in the clutch lever.
- Shift into 1st gear.
- Open the throttle a little, and start to let out the clutch lever very slowly.
- As the clutch starts to engage, open the throttle a little more, giving the engine just enough fuel to keep it from stalling.

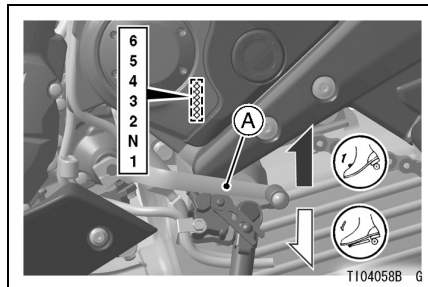

A. Shift Pedal

NOTE

- *The motorcycle is equipped with a side stand switch. This switch is designed so that the engine does not start if the transmission is in gear and the side stand is down.*
- *When the headlight is on high beam, two headlight beams go on, and on low beam, one headlight goes on.*

64 HOW TO RIDE THE MOTORCYCLE

Shifting Gears

- Close the throttle while pulling in the clutch lever.
- Shift into the next higher or lower gear.

WARNING

Downshifting to a lower gear at high speed causes engine rpm to increase excessively, potentially damaging the engine and it may also cause the rear wheel to skid and cause an accident. Downshifting should be done below 5 000 rpm for each gear.

- Open the throttle half way, while releasing the clutch lever.

NOTE

- *The transmission is equipped with a positive neutral finder. When the motorcycle is standing still, the transmission cannot be shifted past neutral from 1st gear. To use the positive neutral finder, shift down to 1st gear, then lift up on the shift pedal while standing still. The transmission will shift only into neutral.*

Braking

- Close the throttle completely, leaving the clutch engaged (except when shifting gears) so that the engine will help slow down the motorcycle.
- Shift down one gear at a time so that you are in 1st gear when you come to a complete stop.
- When stopping, always apply both brakes at the same time. Normally the front brake should be applied a little more than the rear. Shift down or fully disengage the clutch as necessary to keep the engine from stalling.
- Never lock the brakes, or it will cause the tires to skid. When turning a corner, it is better not to brake at all. Reduce your speed before you get into the corner.
- For emergency braking, disregard downshifting, and concentrate on

applying the brakes as hard as possible without skidding.

- Even in motorcycles equipped with ABS, braking during cornering may cause wheel slip. When turning a corner, it is better to limit braking to the light application of both brakes or not to brake at all. Reduce your speed before you get into the corner.

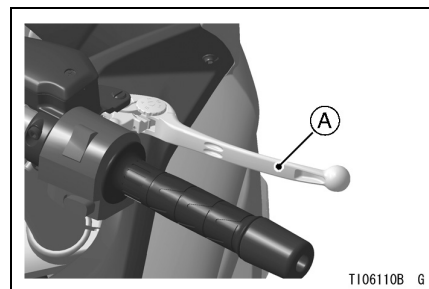

A. Front Brake Lever

66 HOW TO RIDE THE MOTORCYCLE

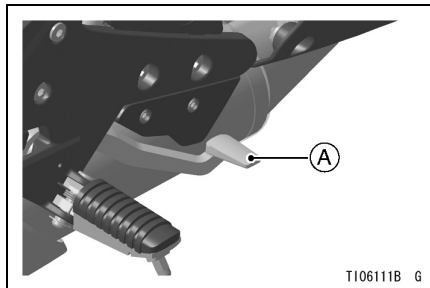

A. Rear Brake Pedal

Anti-lock Brake System (ABS) for models equipped with ABS

ABS is designed to help prevent the wheels from locking up when hard brakes are applied while running straight. The ABS automatically regulates brake force. Intermittently gaining gripping force and braking force helps prevent wheel lock-up and allows stable steering control while stopping.

Brake control function is identical to that of a conventional motorcycle. The brake lever is used for the front brake and the brake pedal for the rear brake.

Although the ABS provides stability while stopping by preventing wheel lock-up, remember the following characteristics:

- ABS cannot compensate for adverse road conditions, misjudgement or improper application of brakes. You

must take the same care as with motorcycles not equipped with ABS.

- ABS is not designed to shorten the braking distance. On loose, uneven or downhill surfaces, the stopping distance of a motorcycle with ABS may be longer than that of an equivalent motorcycle without ABS. Use special caution in such areas.
- ABS will help prevent wheel lock-up during straight-up braking, but it cannot control wheel slip which may be caused by braking during cornering. When turning a corner, it is better to limit braking to the light application of both brakes or not to brake at all. Reduce your speed before you get into the corner.
- The computers integrated in the ABS compare vehicle speed with wheel

speed. Since non-recommended tires can affect wheel speed, they may confuse the computers, which can extend braking distance.

⚠ WARNING

ABS cannot protect the rider from all possible hazards and is not a substitute for safe riding practices. Be aware of how the ABS system operates and its limitations. It is the rider's responsibility to ride at appropriate speeds and manner for weather, road surface and traffic conditions.

⚠ WARNING

Use of non-recommended tires may cause malfunctioning of ABS and can lead to extended braking distance. The rider could have an accident as a result. Always use recommended standard tires for this motorcycle.

NOTE

- *When the ABS is functioning, you may feel a pulsing in the brake lever or pedal. This is normal. You need not suspend applying brakes.*
- *ABS does not function at the speed of approx. 6 km/h or below.*
- *ABS does not function if the battery is discharged.*
- *ABS indicator light may go on under motorcycle riding condition. (ex. The front or rear wheel races.) In*

this case, first turn the ignition key to "OFF", and then back to "ON". ABS indicator light goes off by this operation, but if ABS indicator light stays on after the motorcycle runs at the speed of approx. 6 km/h or below, you should have the ABS checked by an authorized Kawasaki dealer.

Yellow ABS Indicator Light:

Normally the ABS indicator light goes on when the ignition switch is turned on and goes off shortly after the motorcycle starts moving.

If the indicator light shows any of the following, a fault or faults may have taken place in the ABS. You should have the ABS checked by an authorized Kawasaki dealer.

- The light does not go on when the ignition switch is turned on.
- The light stays on lit after the motorcycle starts moving.

- The light goes on and stays on after the motorcycle starts moving.

Remember that the ABS does not function when the indicator light is on, but if the ABS fails, the conventional brake system still works normally.

Stopping the Engine

- Close the throttle completely.
- Shift the transmission into neutral.
- Turn the ignition key to "OFF".
- Support the motorcycle on a firm, level surface with the side stand.
- Lock the steering.

NOTE

- *The motorcycle is equipped with a vehicle-down sensor which causes the engine to stop automatically if the motorcycle falls down. The engine warning indicator light () blinks when the starter button pressed if the engine cannot be started. After righting the motorcycle, first turn the ignition key to "OFF" and then back to "ON" before starting the engine.*

70 HOW TO RIDE THE MOTORCYCLE

Stopping the Motorcycle in an Emergency

Your Kawasaki Motorcycle has been designed and manufactured to provide you optimum safety and convenience. However, in order to fully benefit from Kawasaki's safety engineering and craftsmanship, it is essential that you, the owner and operator, properly maintain your motorcycle and become thoroughly familiar with its operation. Improper maintenance can create a dangerous situation known as throttle failure. Two of the most common causes of throttle failure are:

1. An improperly serviced or clogged air cleaner may allow dirt and dust to enter the throttle body and stick the throttle open.

2. During removal of the air cleaner, dirt is allowed to enter and jam the fuel injection system.

In an emergency situation such as throttle failure, your vehicle may be stopped by applying the brakes and disengaging the clutch. Once this stopping procedure is initiated, the engine stop switch may be used to stop the engine. If the engine stop switch is used, turn off the ignition switch after stopping the motorcycle.

Parking

⚠ WARNING

Operating or parking the vehicle near flammable materials can cause a fire, and can result in property damage or severe personal injury.

Do not idle or park your vehicle in an area where tall or dry vegetation, or other flammable materials could come into contact with the muffler or exhaust pipe.

⚠ WARNING

The engine and exhaust system get extremely hot during normal operation and can cause serious burns.

Never touch a hot engine, exhaust pipe, or muffler during operation or after stopping the engine.

- Shift the transmission into neutral and turn the ignition key to "OFF".
- Support the motorcycle on a firm, level surface with the side stand.

NOTICE

Do not park on a soft or steeply inclined surface, or the motorcycle may fall over.

- If parking inside a garage or other structure, be sure it is well ventilated

72 HOW TO RIDE THE MOTORCYCLE

and the motorcycle is not close to any source of flame or sparks; this includes any appliance with a pilot light.

WARNING

Gasoline is extremely flammable and can be explosive under certain conditions, creating the potential for serious burns. Turn the ignition switch to "OFF". Do not smoke. Make sure the area is well ventilated and free from any source of flame or sparks; this includes any appliance with a pilot light.

- Lock the steering to prevent theft.

NOTE

- *When stopping near traffic at night, you can leave the taillight on for greater visibility by turning the ignition key to the P (park) position.*
- *Do not leave the ignition switch at P position too long, or the battery will discharge.*

Catalytic Converter

This motorcycle is equipped with a catalytic converter in the exhaust system. The converter reacts with carbon monoxide, hydrocarbons and nitrogen oxides to convert them into carbon dioxide, water, nitrogen and oxygen resulting in much cleaner exhaust gases to be discharged into the atmosphere.

For proper operation of the catalytic converter, the following cautions must be observed.

WARNING

Operating or parking the vehicle near flammable materials can cause a fire, and can result in property damage or severe personal injury.

Do not idle or park your vehicle in an area where tall or dry vegetation, or other flammable materials could come into contact with the muffler or exhaust pipe.

WARNING

The engine and exhaust system get extremely hot during normal operation and can cause serious burns.

Never touch a hot engine, exhaust pipe, or muffler during operation or after stopping the engine.

74 HOW TO RIDE THE MOTORCYCLE

- Use only unleaded gasoline. Never use leaded gasoline. Leaded gasoline significantly reduces the capability of the catalytic converter.
- Do not operate the vehicle with the engine or any one cylinder misfiring. Under these conditions unburned

air/fuel mixture flowing out of engine excessively accelerates reaction in the converter allowing the converter to overheat and become damaged when the engine is hot, or reduces converter performance when the engine is cold.

SAFE OPERATION

Safe Riding Technique

The points given below are applicable for everyday motorcycle use and should be carefully observed for safe and effective vehicle operation.

For safety, eye protection and a helmet are strongly recommended. You should be aware of and verify the applicable safety regulations in force prior to riding your motorcycle. Gloves and suitable footwear should also be used for added protection in case of a mishap.

A motorcycle does not provide the impact protection of an automobile, so defensive riding in addition to wearing protective apparel is extremely important. Do not let protective apparel give you a false sense of security.

When riding always keep both hands on the handlebars and both feet on the footpegs. Removing your hands from the handlebars or feet from the footpegs while riding can be hazardous. If you remove even one hand or foot, you can reduce your ability to control the motorcycle.

Before changing lanes, look over your shoulder to make sure the way is clear. Do not rely solely on the rear view mirror; you may misjudge a vehicle's distance and speed, or you may not see it at all.

76 SAFE OPERATION

In general your actions should be smooth as sudden acceleration, braking or turning may cause loss of control, especially when riding in wet conditions or on loose roadway surfaces, when the ability to maneuver will be reduced.

When going up steep slopes, shift to a lower gear so that there is plenty of power to spare rather than overloading the engine.

When applying the brakes, use both the front and rear brakes. Applying only one brake for sudden braking may cause the motorcycle to skid and lose control.

When going down long slopes, control vehicle speed by closing the throttle. Use the front and rear brakes for auxiliary braking.

In wet conditions, rely more on the throttle to control vehicle speed and less on the front and rear brakes. The throttle should also be used judiciously to avoid skidding the rear wheel from too rapid acceleration or deceleration.

Riding at the proper rate of speed and avoiding unnecessarily fast acceleration are important not only for safety and low fuel consumption but also for long vehicle life and quieter operation.

On rough roads, exercise caution, slow down, and grip the fuel tank with the knees for better stability.

When quick acceleration is necessary as in passing, shift to a lower gear to obtain the necessary power.

SAFE OPERATION 77

Do not downshift at too high an r/min (rpm) to avoid damage from overrevving to the engine.

Avoiding unnecessary weaving is important to the safety of both the rider and other motorists.



78 SAFE OPERATION

Daily Safety Checks

Check the following items each day before you ride. The time required is minimal, and habitual performance of these checks will help ensure you a safe, reliable ride.

If any irregularities are found during these checks, refer to the Maintenance and Adjustment chapter or see your dealer for the action required to return the motorcycle to a safe operating condition.

⚠ WARNING

Failure to perform these checks before operation may result in serious damage or an accident. Always perform daily safety checks before operation.

⚠ DANGER

Exhaust gas contains carbon monoxide, a colorless, odorless poisonous gas. Inhaling carbon monoxide can cause serious brain injury or death. Do not run the engine in enclosed areas. Operate only in a well-ventilated area.

- Fuel Adequate supply in tank, no leaks.
- Engine oil Oil level between level lines.
- Tires Air pressure (when cold):

SAFE OPERATION 79

Front	Up to 200 kg (441 lb) Load	225 kPa (2.25 kgf/cm ² , 32 psi)
Rear	Up to 200 kg (441 lb) Load	250 kPa (2.50 kgf/cm ² , 36 psi)

- Drive chain Install the air valve cap.
Slack 25 ~ 35 mm (1.0 ~ 1.4 in.)
Lubricate the drive chain if dry.
- Nuts, bolts, fasteners .. Check that steering and suspension components, axles,
and all controls are properly tightened or fastened.
- Steering Action smooth but not loose from lock to lock.
No binding of control cables.
- Brakes Brake pad wear: Lining thickness more than 1 mm (0.04
in.) left.
No brake fluid leakage.
- Throttle Throttle grip play 2 ~ 3 mm (0.08 ~ 0.12 in.).
- Clutch Clutch lever play 2 ~ 3 mm (0.08 ~ 0.12 in.).
Clutch lever operates smoothly.
- Coolant No coolant leakage.
Coolant level between level lines (when engine is cold).
- Electrical equipment ... All lights (Headlight, Tail/Brake Lights, Turn Signal Lights,
Warning/Indicator Lights) and horn work.
- Engine stop switch Stops engine.

80 SAFE OPERATION

Side stand Returns to its fully up position by spring tension.
Returns spring not weak or not damaged.

 Refer to the "Daily Safety Checks" caution label attached under the passenger's seat.

Additional Considerations for High Speed Operation

Brakes: The importance of the brakes, especially during high speed operation, cannot be overemphasized. Check to see that they are correctly adjusted and functioning properly.

Steering: Looseness in the steering can cause loss of control. Check to see that the handlebar turns freely but has no play.

Tires: High speed operation is hard on tires, and good tires are crucial for riding safety. Examine their overall condition, inflate them to the proper pressure, and check the wheel balance.

Fuel: Have sufficient fuel for the high fuel consumption during high speed operation.

Engine Oil: To avoid engine seizure and resulting loss of control, make sure that the oil level is at the upper level line.

Coolant: To avoid overheating, check that the coolant level is at the upper level line.

Electrical Equipment: Make sure that the headlight, tail/brake light, turn signals, horn, etc., all work properly.

Miscellaneous: Make sure that all nuts and bolts are tight and that all safety related parts are in good condition.

82 SAFE OPERATION

 **WARNING**

Handling characteristics of a motorcycle at high speeds may vary from those you are familiar with at legal highway speeds. Do not attempt high speed operation unless you have received sufficient training and have the required skills.

MAINTENANCE AND ADJUSTMENT

The maintenance and adjustments outlined in this chapter must be carried out and must be done in accordance with the Periodic Maintenance Chart to keep the motorcycle in good running condition. **The initial maintenance is vitally important and must not be neglected.**

With a basic knowledge of mechanics and the proper use of tools, you should be able to carry out many of the maintenance items described in this chapter. If you lack proper experience or doubt your ability, all adjustments, maintenance, and repair work should be completed by a qualified technician.

Please note that Kawasaki cannot assume any responsibility for damage resulting from incorrect or improper adjustment done by the owner.

84 MAINTENANCE AND ADJUSTMENT

Periodic Maintenance Chart

K: Should be serviced by an authorized Kawasaki dealer.

*: For higher odometer readings, repeat at the frequency interval established here.

#: Service more frequently when operating in severe conditions: dusty, wet, muddy, high speed, or frequent starting/stopping.



1. Periodic Inspection (Engine Related Items)

Frequency	Whichever comes first ↓	*Odometer Reading km × 1 000 (mile × 1 000)							See Page
		Every	1 (0.6)	6 (3.75)	12 (7.5)	18 (11.25)	24 (15)	30 (18.75)	
K Valve clearance - inspect		every 42 000 km (26 250 mile)							113
Throttle control system (play, smooth return, no drag) - inspect	year	•		•		•		•	115

MAINTENANCE AND ADJUSTMENT 85

Frequency Operation (Engine Items)	Whichever comes first ↓ Every	*Odometer Reading km × 1 000 (mile × 1 000)							See Page
		1 (0.6)	6 (3.75)	12 (7.5)	18 (11.25)	24 (15)	30 (18.75)	36 (22.5)	
K Engine vacuum synchronization - inspect				•		•		•	118
Idle speed - inspect		•		•		•		•	119
K Fuel leak (fuel hose and pipe) - inspect	year	•		•		•		•	-
K Fuel hoses damage - inspect	year	•		•		•		•	-
K Fuel hoses installation condition - inspect	year	•		•		•		•	-



86 MAINTENANCE AND ADJUSTMENT

Frequency Operation (Engine Items)	Whichever comes first ↓ Every	*Odometer Reading km × 1 000 (mile × 1 000)							See Page
		1 (0.6)	6 (3.75)	12 (7.5)	18 (11.25)	24 (15)	30 (18.75)	36 (22.5)	
Coolant level - inspect		•		•		•		•	105
Coolant leak - inspect	year	•		•		•		•	102
Radiator hoses damage - inspect	year	•		•		•		•	102
Radiator hoses installation condition - inspect	year	•		•		•		•	102

MAINTENANCE AND ADJUSTMENT 87

Frequency Operation (Engine Items)	Whichever comes first ↓ Every	*Odometer Reading km × 1 000 (mile × 1 000)							See Page
		1 (0.6)	6 (3.75)	12 (7.5)	18 (11.25)	24 (15)	30 (18.75)	36 (22.5)	
Evaporative emission control system - function (Southeast Asia B1 and Thailand models only)		•	•	•	•	•	•	•	111
K Air suction system damage - inspect				•		•		•	112



88 MAINTENANCE AND ADJUSTMENT

2. Periodic Inspection (Chassis Related Items)

Operation (Chassis Items)	Frequency ↓ Every	*Odometer Reading km × 1000 (mile × 1000)							See Page
		1 (0.6)	6 (3.75)	12 (7.5)	18 (11.25)	24 (15)	30 (18.75)	36 (22.5)	
Clutch and drive train:									
Clutch operation (play, engagement, disengagement) - inspect		•		•		•		•	120
Drive chain lubrication condition - inspect #		every 600 km (400 mile)							130
Drive chain slack - inspect #		every 1 000 km (600 mile)							124
Drive chain wear - inspect #				•		•		•	128

MAINTENANCE AND ADJUSTMENT 89

Frequency	Whichever comes first ↓	*Odometer Reading km × 1000 (mile × 1000)							See Page
		Every	1 (0.6)	6 (3.75)	12 (7.5)	18 (11.25)	24 (15)	30 (18.75)	
K Drive chain guide wear - inspect				•		•		•	-
Wheels and tires:									
Tire air pressure - inspect	year			•		•		•	143
Wheels/tires damage - inspect				•		•		•	144
Tire tread wear, abnormal wear - inspect				•		•		•	144
K Wheel bearings damage - inspect	year			•		•		•	-



MAINTENANCE AND ADJUSTMENT 91

Frequency Operation (Chassis Items)	Whichever comes first ↓ Every	*Odometer Reading km × 1000 (mile × 1000)							See Page
		1 (0.6)	6 (3.75)	12 (7.5)	18 (11.25)	24 (15)	30 (18.75)	36 (22.5)	
Brake operation (effectiveness, play, drag) - inspect	year	•	•	•	•	•	•	•	135
Brake light switch operation - inspect		•	•	•	•	•	•	•	136
Suspensions:									
Front forks/rear shock absorber operation (damping and smooth stroke) - inspect				•		•		•	138, 139



92 MAINTENANCE AND ADJUSTMENT

Frequency	Whichever comes first ↓	*Odometer Reading km × 1000 (mile × 1000)							See Page
		Every	1 (0.6)	6 (3.75)	12 (7.5)	18 (11.25)	24 (15)	30 (18.75)	
Operation (Chassis Items)									
Front forks/rear shock absorber oil leak - inspect	year			•		•		•	138, 139
Steering System:									
K Steering play - inspect	year	•		•		•		•	-
K Steering stem bearings - lubricate	2 years					•			-
Electrical System:									
Lights and switches operation - inspect	year			•		•		•	-

MAINTENANCE AND ADJUSTMENT 93

Frequency	Whichever comes first ↓	*Odometer Reading km × 1000 (mile × 1000)							See Page	
		Every	1 (0.6)	6 (3.75)	12 (7.5)	18 (11.25)	24 (15)	30 (18.75)		36 (22.5)
Headlight aiming - inspect	year			•			•		•	152
Side stand switch operation - inspect	year			•			•		•	–
Engine stop switch operation - inspect	year			•			•		•	–
Chassis:										
K Chassis parts - lubricate	year			•			•		•	156
K Bolts and nuts tightness - inspect		•		•			•		•	–



94 MAINTENANCE AND ADJUSTMENT

3. Periodic Replacement

Change/Replacement Items	Frequency	*Odometer Reading km × 1 000 (mile × 1 000)					See Page
	Whichever comes first ↓ Every	1 (0.6)	12 (7.5)	24 (15)	36 (22.5)	48 (30)	
K Air cleaner element # - replace	every 18 000 km (11 250 mile)						113
Engine oil # - change	year	•	•	•	•	•	98
Oil filter - replace	year	•	•	•	•	•	98
K Fuel hoses - replace	5 years						–
K Coolant - change	3 years				•		109
K Radiator hoses and O-rings - replace	3 years				•		–
K Brake hoses - replace	4 years					•	–
K Brake fluid (front and rear) - change	2 years			•		•	135

MAINTENANCE AND ADJUSTMENT 95

Change/Replacement Items	Frequency	*Odometer Reading km × 1 000 (mile × 1 000)					See Page
	Whichever comes first ↓ Every	1 (0.6)	12 (7.5)	24 (15)	36 (22.5)	48 (30)	
K Rubber parts of master cylinder and caliper - replace	4 years					•	–
K Spark plug - replace			•	•	•	•	110



96 MAINTENANCE AND ADJUSTMENT

Engine Oil

In order for the engine, transmission, and clutch to function properly, maintain the engine oil at the proper level, and change the oil and replace the oil filter in accordance with the Periodic Maintenance Chart. Not only do dirt and metal particles collect in the oil, but the oil itself loses its lubricative quality if used too long.

WARNING

Motorcycle operation with insufficient, deteriorated, or contaminated engine oil will cause accelerated wear and may result in engine or transmission seizure, accident, and injury. Check the oil level before each ride and change the oil according to the periodic maintenance chart in the owner's manual.

Oil Level Inspection

- If the oil has just been changed, start the engine and run it for several minutes at idle speed. This fills the oil filter with oil. Stop the engine, then wait several minutes until the oil settles.

NOTICE

Racing the engine before the oil reaches every part can cause engine seizure.

- If the motorcycle has just been used, wait several minutes for all the oil to drain down.

- Check the engine oil level through the oil level inspection window. With the motorcycle held level, the oil level should come up between the upper and lower level lines next to the gauge.

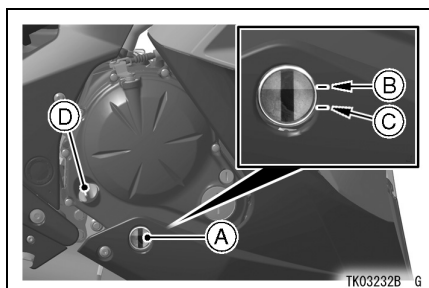

- A. Oil Level Inspection Window
- B. Upper Level Line
- C. Lower Level Line
- D. Oil Filler Cap

- If the oil level is too high, remove the excess oil through the oil filler opening using a syringe or some other suitable device.
- If the oil level is too low, add the oil to reach the correct level. Use the same type and brand of oil that is already in the engine.

NOTICE

If the engine oil gets extremely low or if the oil pump does not function properly or oil passages are clogged, the warning indicator light () will go on. If this warning indicator light stays on when the engine speed is slightly above the idle speed, stop the engine immediately and find the cause.

98 MAINTENANCE AND ADJUSTMENT

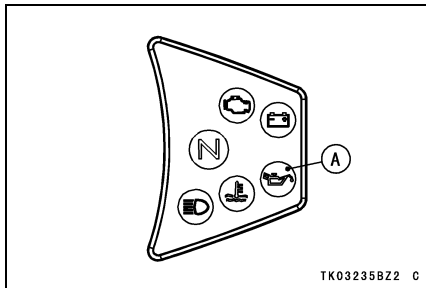

A. Red Oil Pressure Warning Indicator Light

Oil and/or Oil Filter Change

- Warm up the engine thoroughly, and then stop it.
- Place an oil pan beneath the engine.
- Remove the engine oil drain plug.

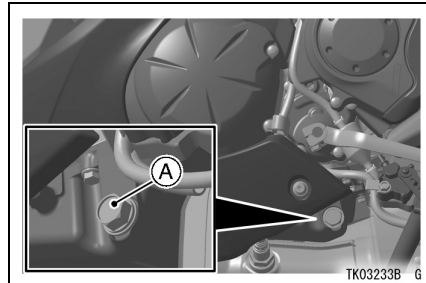

A. Drain Plug

- Let the oil completely drain with the motorcycle perpendicular to the ground.

⚠ WARNING

Engine oil is a toxic substance. Dispose of used oil properly. Contact your local authorities for approved disposal methods or possible recycling.

- Remove the right side fairing (refer to the “Cooling System” section in this chapter).
- Remove the oil filter cartridge and replace it with a new one.

NOTE

○ *If a torque wrench or required Kawasaki special tool is not available, this item should be serviced by an authorized Kawasaki dealer.*

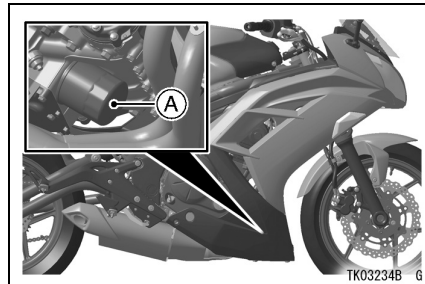

A. Oil Filter Cartridge

100 MAINTENANCE AND ADJUSTMENT

- Apply a thin film of oil to the packing and tighten the cartridge to the specified torque.

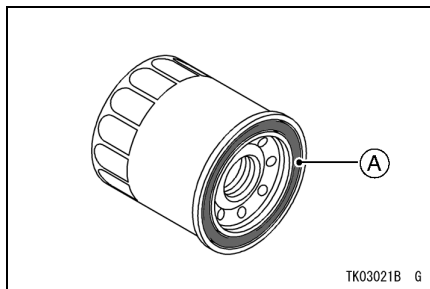

A. Packing

- Install the drain plug with its new gasket. Tighten it to the specified torque.

NOTE

- Replace any gaskets with new ones.

- Fill the engine up to the upper level line with a good quality engine oil specified in the table.
- Start the engine.
- Check the oil level and oil leakage.

Tightening Torque

Engine Oil Drain Plug :

30 N·m (3.1 kgf·m, 22 ft·lb)

Oil Filter Cartridge :

17.5 N·m (1.75 kgf·m, 13 ft·lb)

Recommended Engine Oil

Type : API SG, SH, SJ, SL or SM
with JASO MA, MA1 or
MA2

Viscosity : SAE 10W-40

NOTE

- Do not add any chemical additive to the oil. Oils fulfilling the above requirements are fully formulated and

MAINTENANCE AND ADJUSTMENT 101

provide adequate lubrication for both the engine and the clutch.

Engine Oil Capacity

Capacity :	1.6 L (1.7 US qt)
	[when filter is not removed]
	1.8 L (1.9 US qt)
	[when filter is removed]
	2.3 L (2.4 US qt)
	[when engine is completely dry]

- Install the right side fairing (refer to the “Cooling System” section in this chapter).

Although 10W-40 engine oil is the recommended oil for most conditions, the oil viscosity may need to be changed to accommodate atmospheric conditions in your riding area.

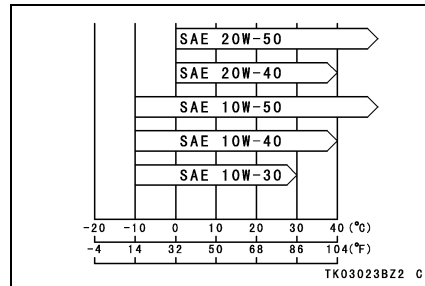

102 MAINTENANCE AND ADJUSTMENT

Cooling System

Radiator and Cooling Fan -

Check the radiator fins for obstruction by insects or mud. Clean off any obstructions with a stream of low-pressure water.

WARNING

The cooling fan spins at high speed and can cause serious injuries. Keep your hands and clothing away from the cooling fan blades at all times.

NOTICE

Using high-pressure water, as from a car wash facility, could damage the radiator fins and impair the radiator's effectiveness. Do not obstruct or deflect airflow through the radiator by installing unauthorized accessories in front of the radiator or behind the cooling fan. Interference with the radiator airflow can lead to overheating and consequent engine damage.

Radiator Hoses -

Check the radiator hoses for leakage, cracks or deterioration, and connections for leakage or looseness each day before riding the motorcycle, and carry out the maintenance and adjustments in accordance with the Periodic Maintenance Chart.

Coolant -

Coolant absorbs excessive heat from the engine and transfers it to the air at the radiator. If the coolant level becomes low, the engine overheats and may suffer severe damage. Check the coolant level each day before riding the motorcycle, and carry out the maintenance and adjustments in accordance with the periodic maintenance chart. Replenish coolant if the level is low. Change the coolant in accordance with the Periodic Maintenance Chart.

Information for Coolant

To protect the cooling system (consisting of the aluminum engine and radiator) from rust and corrosion, the use of corrosion and rust inhibitor chemicals in the coolant is essential. If coolant containing corrosion and rust inhibitor chemicals is not used, over a

period of time, the cooling system accumulates rust and scale in the water jacket and radiator. This will clog up the coolant passages, and considerably reduce the efficiency of the cooling system.

⚠ WARNING

Coolant containing corrosion inhibitors for aluminum engines and radiators include harmful chemicals for human body. Drinking coolant can result in serious injury or death. Use coolant in accordance with the instructions of the manufacturer.

Soft or distilled water must be used with the antifreeze (see below for antifreeze) in the cooling system.

104 MAINTENANCE AND ADJUSTMENT

NOTICE

If hard water is used in the system, it causes scale accumulation in the water passages, and considerably reduces the efficiency of the cooling system.

If the lowest ambient temperature encountered falls below the freezing point of water, use permanent antifreeze in the coolant to protect the cooling system against engine and radiator freeze-up, as well as from rust and corrosion.

Use a permanent type of antifreeze (soft water and ethylene glycol plus corrosion and rust inhibitor chemicals for aluminum engines and radiators) in the cooling system. On the mixture ratio of coolant, choose the suitable one referring to the relation between freezing point and strength directed on the container.

NOTICE

Permanent types of antifreeze on the market have anti-corrosion and anti-rust properties. When it is diluted excessively, it loses its anti-corrosion property. Dilute a permanent type of antifreeze in accordance with the instructions of the manufacturer.

NOTE

- A permanent type of antifreeze is installed in the cooling system when shipped. It is colored green and contains ethylene glycol. It is mixed at 50% and has the freezing point of -35°C (-31°F).

Coolant Level Inspection

- Situate the motorcycle so that it is perpendicular to the ground.
- Check the coolant level if it is between the F (Full) and L (Low) level lines on the reserve tank located right side of the radiator.

NOTE

- Check the level when the engine is cold (room or atmospheric temperature).

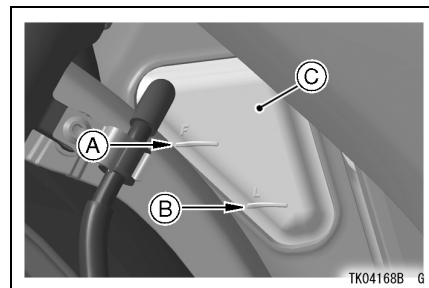

- A. F (Full) Level Line
- B. L (Low) Level Line
- C. Coolant Reserve Tank

- If the amount of coolant is insufficient, remove the right side fairing and add coolant into the reserve tank.

106 MAINTENANCE AND ADJUSTMENT

Coolant Filling

- Remove three large quick rivets on the bottom of the fairing. The large quick rivets can be removed by pulling the center pin with a screw driver.
- Remove three small quick rivets behind the right side fairing. The small quick rivets can be removed by pushing the center pin into the rivet.

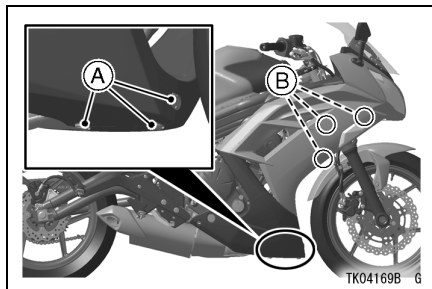

A. Large Quick Rivets
B. Small Quick Rivets

NOTE

- When installing the large quick rivet, insert them into the holes on the fairing and push the center pin to secure them.
- When installing the small quick rivets, pull the center pin fully up first, and push the center pin after inserting them.

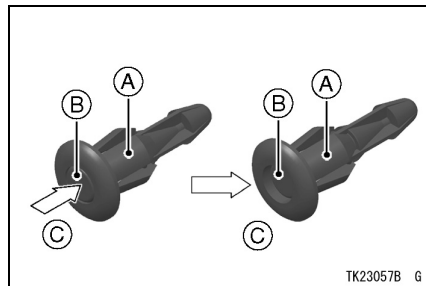

A. Quick Rivet
B. Center Pin
C. Push in.

MAINTENANCE AND ADJUSTMENT 107

- Remove the right side fairing mounting bolts, nylon washers and collars.

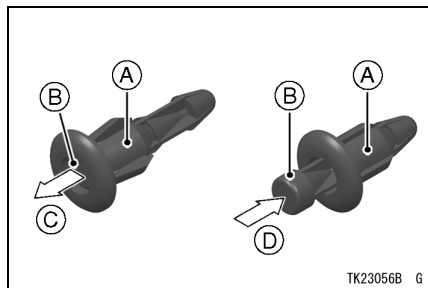

- A. Quick Rivet
- B. Center Pin
- C. Pull up fully.
- D. Push in.

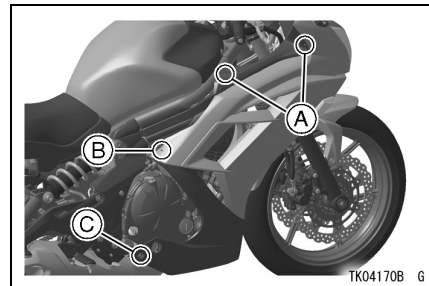

- A. Bolts (Black) and Nylon Washers
- B. Bolt and Collar
- C. Bolt, Nylon Washer and Collar

108 MAINTENANCE AND ADJUSTMENT

- Slide the upper edge of the right side fairing rearward carefully to detach all tabs from the holes on the fairings.
- Disconnect the right turn signal light connector and remove the right side fairing.

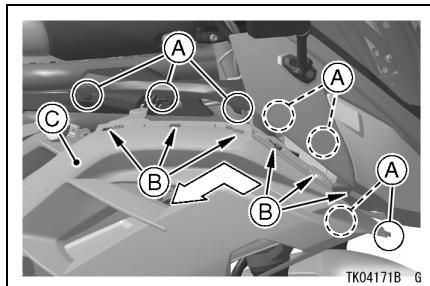

- A. Tabs
- B. Holes
- C. Right Side Fairing

- Remove the cap from the reserve tank and add coolant through the filler opening to the F (Full) level line.

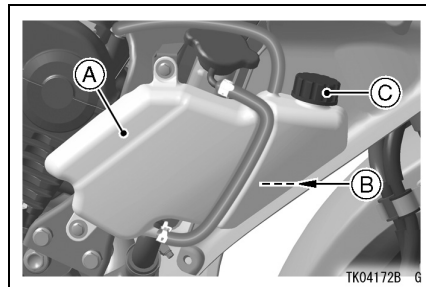

- A. Reserve Tank
- B. F (Full) Level Line
- C. Cap

- Position the right side fairing aligning the tabs with the holes carefully.
- Install the three small quick rivets behind the right side fairing and three large quick rivets at the bottom of the fairing.

- Install the mounting bolts, nylon washers and collars to secure right side fairing.

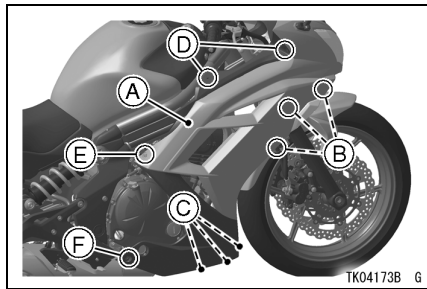

- A. Right Side Fairing
- B. Small Quick Rivets
- C. Large Quick Rivets
- D. Bolts (Black) and Nylon Washers
- E. Bolt and Collar
- F. Bolt, Nylon Washer and Collar

NOTE

- *In an emergency you can add water alone to the coolant reserve tank, however it must be returned to the correct mixture ratio by the addition of antifreeze concentrate as soon as possible.*

NOTICE

If coolant must be added often, or the reserve tank completely runs dry, there is probably leakage in the system. Have the cooling system inspected by your authorized Kawasaki dealer.

Coolant Change

Have the coolant changed by an authorized Kawasaki dealer.

110 MAINTENANCE AND ADJUSTMENT

Spark Plugs

The standard spark plug is shown in the table. The spark plugs should be replaced in accordance with the Periodic Maintenance Chart.

Spark plug removal should be done by an authorized Kawasaki dealer.

Spark Plug

Standard Plug	NGK CR9EIA-9
Plug Gap	0.8 ~ 0.9 mm (0.032 ~ 0.035 in.)
Tightening Torque	15 N·m (1.5 kgf·m, 11 ft·lb)

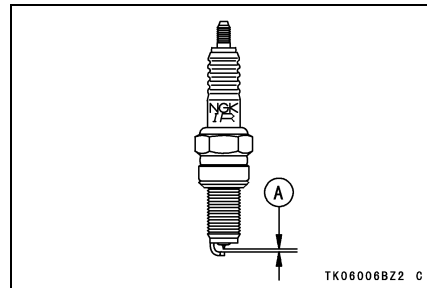

A. Plug Gap

Evaporative Emission Control System (Southeast Asia B1 and Thailand models only)

This system routes fuel vapors from the fuel system into the running engine or stores the vapors in a canister when the engine is stopped. Although no adjustments are required, a thorough visual inspection must be made at the intervals specified by the Periodic Maintenance Chart.

Inspection

- Check that the hoses are securely connected.
- Replace any kinked, deteriorated, or damaged hoses.

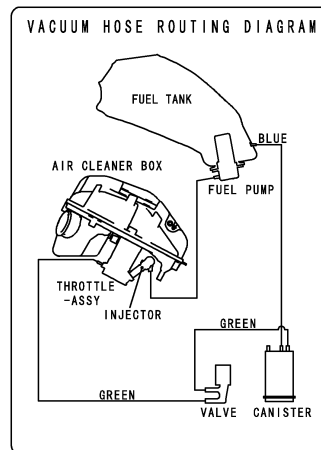

59465-0562

TE03113DN7 C

112 MAINTENANCE AND ADJUSTMENT

Kawasaki Clean Air System

The Kawasaki Clean Air System (KCA) is a secondary air suction system that helps the exhaust gases to burn more completely. When the spent fuel charge is released into the exhaust system, it is still hot enough to burn. The KCA System allows extra air into the exhaust system so that the spent fuel charge can continue to burn. This continued burning action tends to burn up a great deal of the normally unburned gases, as well as changing a significant portion of the carbon monoxide into carbon dioxide.

Air Suction Valves -

The air suction valve is essentially a check valve which allows fresh air to flow only from the air cleaner into the exhaust port. Any air that has passed

the air suction valve is prevented from returning. Inspect the air suction valves in accordance with the Periodic Maintenance Chart. Also, inspect the air suction valves whenever stable idling cannot be obtained, engine power is greatly reduced, or there are abnormal engine noises.

Air suction valve removal and inspection should be done by an authorized Kawasaki dealer.

Valve Clearance

Valve and valve seat wear decreases valve clearance, upsetting valve timing.

NOTICE

If valve clearance is left unadjusted, wear will eventually cause the valves to remain partly open, which lowers performance, burns the valves and valve seats, and may cause serious engine damage.

Valve clearance for each valve should be checked and adjusted in accordance with the Periodic Maintenance Chart.

Inspection and adjustment should be done by an authorized Kawasaki dealer.

Air Cleaner

A clogged air cleaner restricts the engine's air intake, increasing fuel consumption, reducing engine power, and causing spark plug fouling.

The air cleaner element must be replaced in accordance with the Periodic Maintenance Chart. This motorcycle's air cleaner element consists of a wet paper filter, which cannot be cleaned. In dusty, rainy, or on muddy conditions, the air cleaner element should be serviced more frequently than the recommended interval.

114 MAINTENANCE AND ADJUSTMENT

NOTICE

Use only the recommended air cleaner element (Kawasaki part number 11013-0713 or equivalent type). Using the any other air cleaner element will wear the engine prematurely or lower the engine performance.

Oil Draining

- Inspect the drain hose located on the left side of the engine to see if any oil or water has run down from the air cleaner housing.

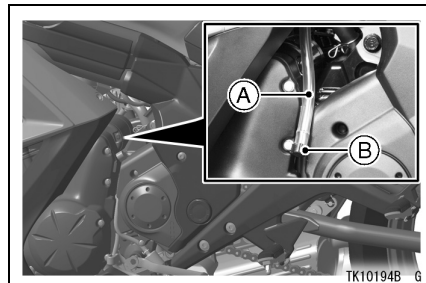

- A. Drain Hose
- B. Plug

- If there is any oil in the hose, remove the plug and drain the oil.

⚠ WARNING

Oil on tires will make them slippery and can cause an accident and injury. Be sure to install the plug in the drain hose after draining.

Throttle Control System

Check the throttle grip play in accordance with the Periodic Maintenance Chart, and adjust it if necessary.

Throttle Grip -

The throttle grip controls the butterfly valves in the throttle body. If the throttle grip has excessive play due to either cable stretch or maladjustment, it will cause a delay in throttle response, especially at low engine speed. Also, the throttle valve may not open fully at full throttle. On the other hand, if the throttle grip has not play, the throttle will be hard to control, and the idle speed will be erratic.

116 MAINTENANCE AND ADJUSTMENT

Inspection

- Check that the throttle grip play is correct by lightly turning the throttle grip back and forth.

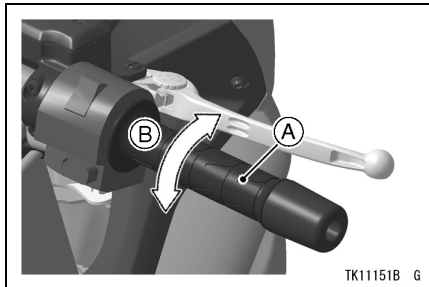

- A. Throttle Grip
- B. Throttle Grip Play

Throttle Grip Play

2 ~ 3 mm (0.08 ~ 0.12 in.)

- If there is improper play, adjust it.

Adjustment

- Loosen the locknut at the throttle grip, and turn the adjuster until the proper amount of throttle grip play is obtained.

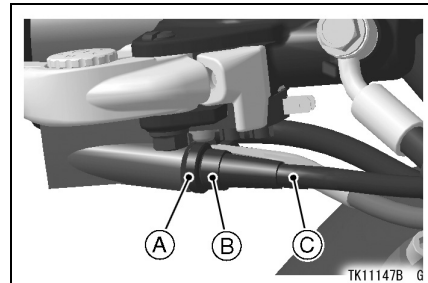

- A. Locknut
- B. Adjuster
- C. Throttle Cable (Accelerator Cable)

MAINTENANCE AND ADJUSTMENT 117

- If the throttle grip play cannot be adjusted with the accelerator cable adjuster at the throttle grip, use the decelerator cable adjuster located under the fuel tank.
- Remove the right side fairing (refer to the “Cooling System” section in this chapter).
- Turn out the decelerator cable adjusting nut until there is no play when the throttle grip is completely closed.
- Tighten the locknut.

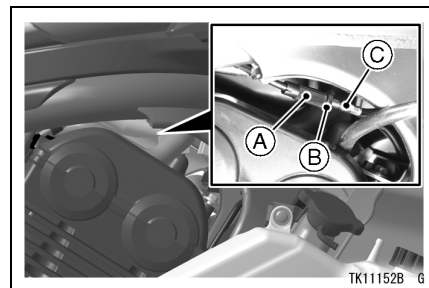

- A. Adjuster**
- B. Locknut**
- C. Throttle Cable (Decelerator Cable)**

- Turn the accelerator cable adjusting nut until a play of 2 ~ 3 mm (0.08 ~ 0.12 in.) is obtained at the throttle grip.
- Tighten the locknut.
- With the engine idling, turn the handlebar to each side. If handlebar movement changes the idle speed, the throttle cables may be improperly

118 MAINTENANCE AND ADJUSTMENT

adjusted or incorrectly routed, or they may be damaged. Be sure to correct any of these conditions before idling.



⚠ WARNING

Operation with improperly adjusted, incorrectly routed, or damaged cables could result in an unsafe riding condition. Be sure the control cables are adjusted and routed correctly, and are free from damage.

- Install the right side fairing (refer to the “Cooling System” section in this chapter).

Engine Vacuum Synchronization

Engine vacuum synchronization must be checked and adjusted periodically in accordance with the Periodic Maintenance Chart by an authorized Kawasaki dealer.

NOTE

- *Poor engine vacuum synchronization will cause unstable idling, sluggish throttle response, and reduce engine power and performance.*

Idle Speed

The idle speed check should be performed in accordance with the Periodic Maintenance Chart or whenever the idle speed is disturbed.

Adjustment

- Start the engine, and warm it up thoroughly.
- Adjust the idle speed by turning the idle adjusting screw.

Idle Speed

1 250 ~ 1 350 r/min (rpm)

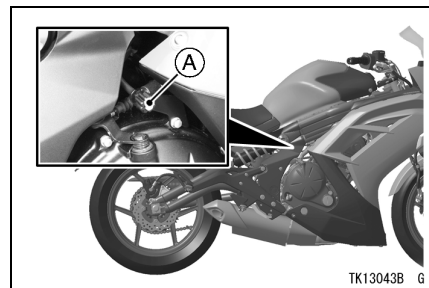

A. Idle Adjusting Screw

- Open and close the throttle a few times to make sure that the idle speed does not change. Readjust if necessary.
- With the engine idling, turn the handlebar to each side. If handlebar movement changes the idle speed, the throttle cables may be improperly adjusted or incorrectly routed, or they may be damaged. Be sure to correct any of these conditions before riding.

120 MAINTENANCE AND ADJUSTMENT

 **WARNING**

Operation with damaged cables could result in an unsafe riding condition. Replace damaged control cables before operation.

Clutch

Due to friction plate wear and clutch cable stretch over a long period of use, the clutch operation should be checked each day before riding the motorcycle, and carry out the maintenance and adjustments in accordance with the Periodic Maintenance Chart.

 **WARNING**

The engine and exhaust system get extremely hot during normal operation and can cause serious burns. Never touch a hot engine or an exhaust pipe during clutch adjustment.

Inspection

- Check that the clutch lever operates properly and that the inner cable slides smoothly. If there is any irregularity, have the clutch cable checked by an authorized Kawasaki dealer.
- Check the clutch lever play as shown in the figure.

Clutch Lever Play

2 ~ 3 mm (0.08 ~ 0.12 in.)

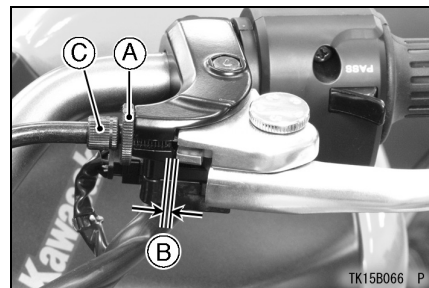

- A. Locknut
- B. Clutch Lever Play
- C. Adjuster

If the play is incorrect, adjust the lever play as follows.

Adjustment

- Loosen the locknut, and turn the adjuster so that the clutch lever will have the proper play.

122 MAINTENANCE AND ADJUSTMENT

⚠ WARNING

Too much cable play can prevent clutch disengagement and cause an accident resulting in serious injury or death. When adjusting the clutch or replacing the cable, be sure the upper end of the clutch outer cable is fully seated in its fitting, or it could slip into place later, creating enough cable play to prevent clutch disengagement.

- If it cannot be done, use the adjuster at the lower end of the clutch cable.
- Remove the right side fairing (refer to the "Cooling System" section in this chapter).
- Loosen the locknut and turn the adjuster to adjust the clutch lever play.
- Tighten the locknut while holding the adjuster with a wrench.

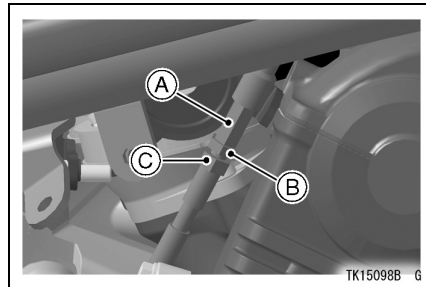

- A. Adjuster
- B. Locknut
- C. Clutch Cable

NOTE

- *After the adjustment is made, start the engine and check that the clutch does not slip and releases properly.*
- *For minor corrections, use the adjuster at the clutch lever.*
- Install the right side fairing (refer to the “Cooling System” section in this chapter).

Drive Chain

The drive chain slack and lubrication must be checked each day before riding the motorcycle, and must be maintained in accordance with the Periodic Maintenance Chart for safety and to prevent excessive wear. If the chain becomes badly worn or maladjusted - either too loose or too tight - the chain could jump off the sprockets or break.

⚠ WARNING

A chain that breaks or jumps off the sprockets could snag on the engine sprocket or lock the rear wheel, severely damaging the motorcycle and causing it to go out of control. Inspect the chain for damage and proper adjustment before each ride.

124 MAINTENANCE AND ADJUSTMENT

Chain Slack Inspection

- Set the motorcycle up on its side stand.
- Rotate the rear wheel to find the position where the chain is tightest, and measure the maximum chain slack by pulling up and pushing down the chain midway between the engine sprocket and rear wheel sprocket.

- If the drive chain is too tight or too loose, adjust it so that the chain slack will be within the standard value.

Drive Chain Slack

Standard	25 ~ 35 mm (1.0 ~ 1.4 in.)
----------	----------------------------

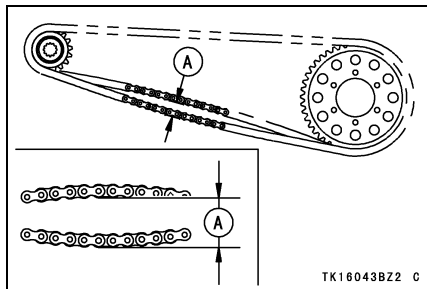

A. Chain Slack

MAINTENANCE AND ADJUSTMENT 125

Chain Slack Adjustment

- Loosen the left and right chain adjuster locknuts.
- Remove the cotter pin, and loosen the axle nut.

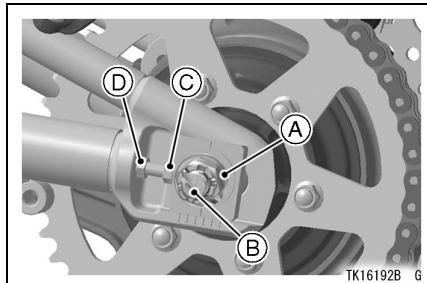

- A. Axle Nut**
- B. Cotter Pin**
- C. Adjuster**
- D. Locknut**

- If the chain is too loose, turn out the left and right chain adjusters evenly.
- If the chain is too tight, turn in the left and right chain adjusters evenly.
- Turn out both chain adjusters evenly until the drive chain has the correct amount of slack. To keep the chain and wheel properly aligned, the notch on the left wheel alignment indicator should align with the same swingarm mark that the right indicator notch aligns with.

126 MAINTENANCE AND ADJUSTMENT

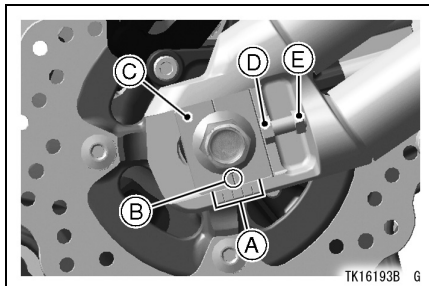

- A. Marks
- B. Notch
- C. Indicator
- D. Adjuster
- E. Locknut

NOTE

- *Wheel alignment can also be checked using the straightedge or string method.*

⚠ WARNING

Misalignment of the wheel will result in abnormal wear, and may result in an unsafe riding condition. Align the rear wheel using the marks on the swingarm or measuring the distance between the center of the axle and swingarm pivot.

- Tighten both chain adjuster locknuts.
- Tighten the rear axle nut to the specified torque.

Tightening Torque

Axle Nut:

108 N·m (11 kgf·m, 80 ft·lb)

NOTE

- *If a torque wrench is not available, this item should be serviced by an authorized Kawasaki dealer.*

MAINTENANCE AND ADJUSTMENT 127

- Rotate the wheel, measure the chain slack again at the tightest position, and readjust if necessary.
- Install a new cotter pin through the rear axle nut and axle, and spread its ends.

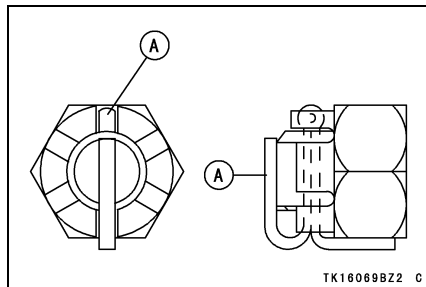

A. Cotter Pin

NOTE

- *When inserting the cotter pin, if the slots in the nut do not align with the cotter pin hole in the axle shaft, tighten the nut clockwise up to the next alignment.*
- *It should be within 30 degrees.*
- *Loosen once and tighten again when the slot goes past the nearest hole.*

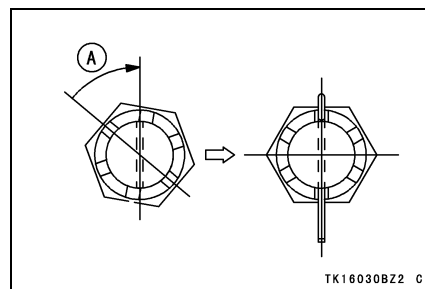

A. Turning Clockwise

128 MAINTENANCE AND ADJUSTMENT

WARNING

A loose axle nut can lead to an accident resulting in serious injury or death. Tighten the axle nut to the proper torque and install a new cotter pin.

- Check the rear brake (see the Brakes section).

Wear Inspection

- Remove the bolts and chain cover.

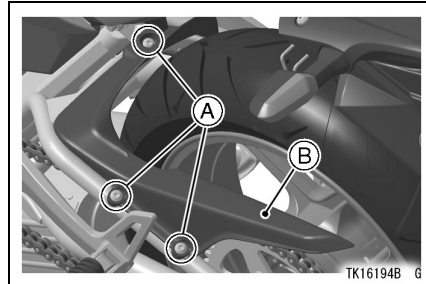

A. Bolts

B. Chain Cover

- Stretch the chain taut either by using the chain adjusters, or by hanging a 10 kg (22 lb) weight on the chain.
- Measure the length of 20 links on the straight part of the chain from pin center of the 1st pin to pin center of the 21st pin. Since the chain may

wear unevenly, take measurements at several places.

- If the length exceeds the service limit, the chain should be replaced.

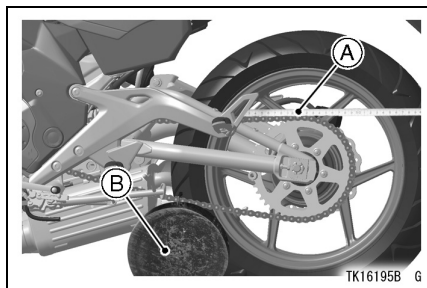

- A. Measure
- B. Weight

Drive Chain 20-Link Length

Service Limit: 323 mm (12.7 in.)

⚠ WARNING

For safety, use only the standard chain. It is an endless type and should not be cut for installation; have it installed by an authorized Kawasaki dealer.

- Install the chain cover and bolts.
- Rotate the rear wheel to inspect the drive chain for damaged rollers, and loose pins and links.
- Also inspect the sprockets for unevenly or excessively worn teeth, and damaged teeth.

130 MAINTENANCE AND ADJUSTMENT

NOTE

○ *Sprocket wear is exaggerated for illustration. See Service Manual for wear limits.*

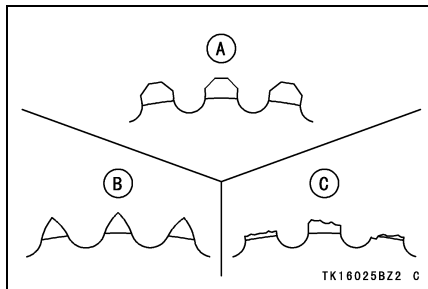

- A. Good Teeth
- B. Worn Teeth
- C. Damaged Teeth

- If there is any irregularity, have the drive chain and/or the sprockets replaced by an authorized Kawasaki dealer.

Lubrication

Lubrication is also necessary after riding through rain or on wet roads, or any time that the chain appears dry. A heavy oil such as SAE 90 is preferred to a lighter oil because it will stay on the chain longer and provide better lubrication.

- Apply oil to the sides of the rollers so that it will penetrate to the rollers and bushings. Apply oil to the O-rings so that the O-rings will be coated with oil. Wipe off any excess oil.

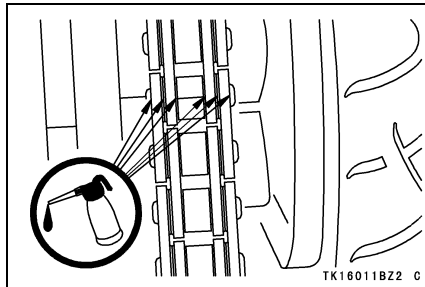

- If the chain is especially dirty, clean it using diesel oil or kerosine and then apply oil as mentioned above.

Brakes

Brake Wear Inspection

Inspect the brakes for wear. For each front and rear disc brake caliper, if the thickness of either pad is less than 1 mm (0.04 in.), replace both pads in the caliper as a set. Pad replacement should be done by an authorized Kawasaki dealer.

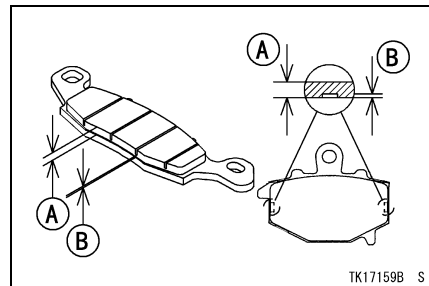

- A. Lining Thickness
- B. 1 mm (0.04 in.)

132 MAINTENANCE AND ADJUSTMENT

Brake Fluid -

In accordance with the Periodic Maintenance Chart, inspect the brake fluid level in both the front and rear brake fluid reservoirs and change the brake fluid. The brake fluid should also be changed if it becomes contaminated with dirt or water.

Fluid Requirement

Use heavy-duty brake fluid only from a container marked DOT4.

NOTICE

Do not spill brake fluid onto any painted surface.

Do not use fluid from a container that has been left open or that has been unsealed for a long time.

Check for fluid leakage around the fittings.

Check brake hose for damage.

Fluid Level Inspection

- The brake fluid level in the front brake fluid reservoir must be kept above the line (lower level line) next to the gauge and that in the rear brake fluid reservoir (located under the rider's seat) must be kept between the upper and lower level lines (reservoirs held horizontal).

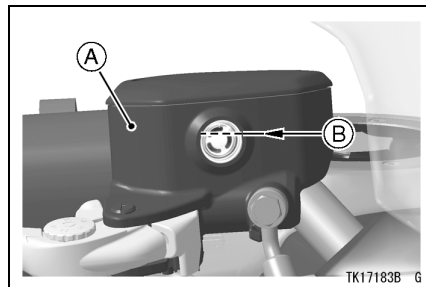

A. Front Brake Fluid Reservoir
B. Lower Level Line

MAINTENANCE AND ADJUSTMENT 133

- If the fluid level in either reservoir is lower than the lower level line, check for fluid leaks in the brake lines, and fill the reservoir to the upper level line. Inside the front brake fluid reservoir is a stepped line showing the upper level line.

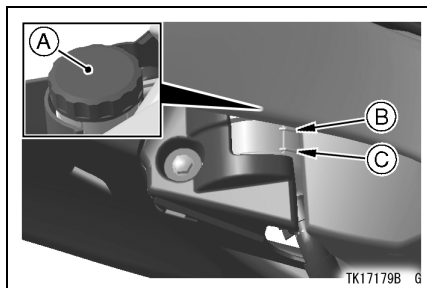

A. Rear Brake Fluid Reservoir
B. Upper Level Line
C. Lower Level Line

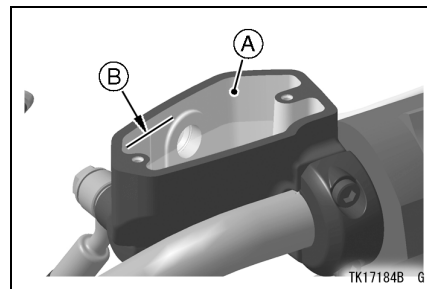

A. Front Brake Fluid Reservoir
B. Upper Level Line

134 MAINTENANCE AND ADJUSTMENT

⚠ WARNING

Mixing brands and types of brake fluid can reduce the brake system's effectiveness and cause an accident resulting in injury or death. Do not mix two brands of brake fluid. Change the brake fluid in the brake line completely if the brake fluid must be refilled but the type and brand of the brake fluid that is already in the reservoir are unidentified.

NOTE

○ First, tighten until slight resistance is felt, which indicates that the cap is seated on the reservoir body; then, tighten the cap an additional 1/6 turn while holding the brake fluid reservoir body.

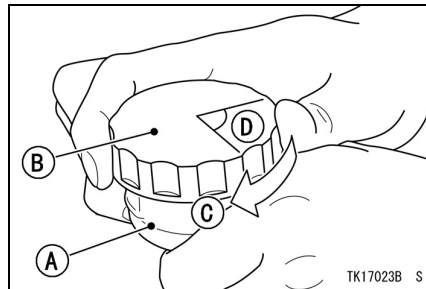

- A. Reservoir
- B. Cap
- C. Clockwise
- D. 1/6 turn

Fluid Change

Have the brake fluid changed by an authorized Kawasaki dealer.

Front and Rear Brakes -

Disc and disc pad wear is automatically compensated for and has no effect on the brake lever or pedal action. So there are no parts that require adjustment on the front brakes and rear brakes.

 **WARNING**

Air in the brake lines diminish braking performance and can cause an accident resulting in injury or death. If the brake lever or pedal feels mushy when it is applied, there might be air in the brake lines or the brake may be defective. Have the brake checked immediately by an authorized Kawasaki dealer.



136 MAINTENANCE AND ADJUSTMENT

Brake Light Switches

When either the front or rear brake is applied, the brake light goes on. The front brake light switch requires no adjustment, but the rear brake light switch should be adjusted in accordance with the Periodic Maintenance Chart.

Inspection

- Turn the ignition key to "ON".
- The brake light should go on when the front brake is applied.
- If it does not, ask your authorized Kawasaki dealer to inspect the front brake light switch.
- Check the operation of the rear brake light switch by depressing the brake pedal. The brake light should go on after the proper pedal travel.

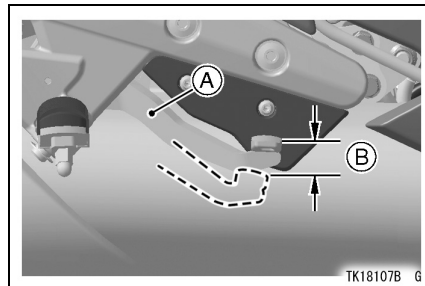

A. Brake Pedal
B. Pedal Travel

- If it does not, adjust the rear brake light switch.

Brake Pedal Travel

10 mm (0.4 in.)

MAINTENANCE AND ADJUSTMENT 137

Adjustment

- To adjust the rear brake light switch, remove bolt and the right frame side cover.

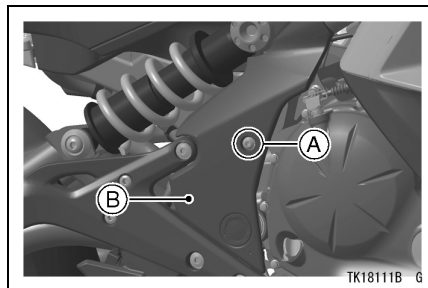

- A. Bolt**
- B. Right Frame Side Cover**

- Move the switch up or down by turning the switch body.

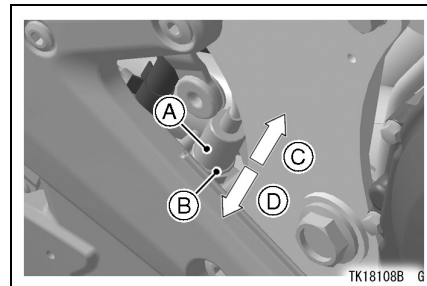

- A. Rear Brake Light Switch**
- B. Adjusting Nut**
- C. Lights sooner**
- D. Lights later**

- Reinstall the right frame side cover and bolt.

NOTICE

To avoid damaging the electrical connections inside the switch, be sure that the switch body does not turn during adjustment.

Front Fork

The front fork operation and oil leakage should be checked in accordance with the Periodic Maintenance Chart.

Front Fork Inspection

- Holding the brake lever, pump the front fork up and down several times to inspect smooth stroke.
- Visually inspect the front fork for oil leakage, scoring or scratches on the outer surface of the inner tube.
- If any doubt about the front fork, it should be checked by an authorized Kawasaki dealer.

Rear Shock Absorber

The rear shock absorber should be checked operation and oil leakage in accordance with the Periodic Maintenance Chart.

Rear Shock Absorber Inspection

- Press down on the seat several times to check if the rear shock absorber stroke is smooth.
- Visually inspect the rear shock absorber for oil leaks.
- If there is any doubt about the rear shock absorber, it should be inspected by an authorized Kawasaki dealer.

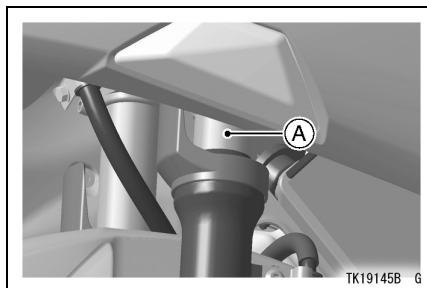

A. Inner Tube

140 MAINTENANCE AND ADJUSTMENT

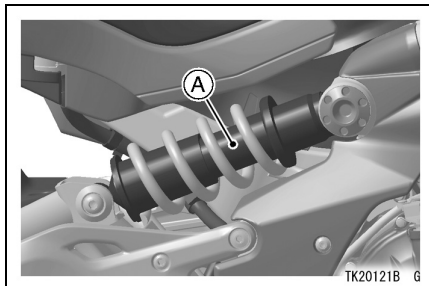

A. Rear Shock Absorber

The rear shock absorber can be adjusted by changing the spring preload and rebound damping force for various riding and loading conditions.

Spring Preload Adjustment

The spring preload adjuster on the rear shock absorber has 7 positions.

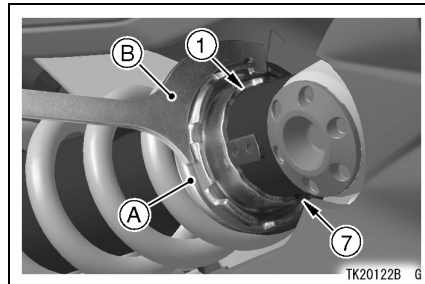

A. Spring Preload Adjuster

B. Wrench

- In accordance with the following table, turn the preload adjuster with the wrench from the tool kit.

Spring Preload Setting

Adjuster Position	1	2	3	4	5	6	7
Spring Action	Weak		← Standard →	Strong			
Setting	Soft		← Standard →	Hard			
Load	Light		← Standard →	Heavy			
Road	Good		← Standard →	Bad			
Speed	Low		← Standard →	High			



142 MAINTENANCE AND ADJUSTMENT

Wheels

Tubeless tires are installed on the wheels of this motorcycle. The indications of TUBELESS on the tire side wall and the rim show that the tire and rim are specially designed for tubeless use.

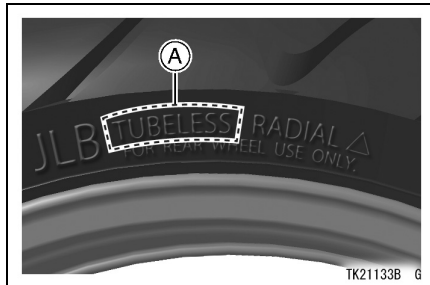

A. TUBELESS Mark

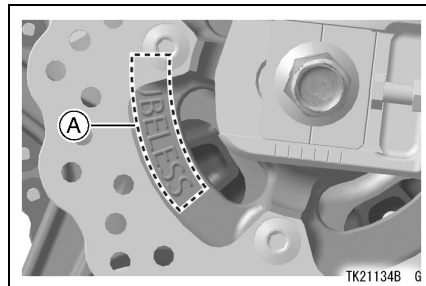

A. TUBELESS Mark

The tire and rim form a leakproof unit by making airtight contacts at the tire chamfers and the rim flanges instead of using an inner tube.

⚠ WARNING

Installing a tube inside a tubeless-type tire can create excessive heat build up that can damage the tube and cause rapid deflation. The tires, rims, and air valves on this motorcycle are designed only for tubeless type wheels. The recommended standard tires, rims, and air valves must be used for replacement. Do not install tube-type tires on tubeless rims. The beads may not seat properly on the rim causing tire deflation. Do not install a tube inside a tubeless tire. Excessive heat build-up may damage the tube causing tire deflation.

Tires -

Payload and Tire Pressure

Failure to maintain proper inflation pressures or observe payload limits for your tires may adversely affect handling and performance of your motorcycle and can result in loss of control. The maximum recommended load in addition to vehicle weight is 200 kg (441 lb), including rider, passenger, baggage, and accessories.

- Remove the air valve cap.
- Check the tire pressure often, using an accurate gauge.
- Make sure to install the air valve cap securely.

NOTE

- *Measure the tire pressure when the tires are cold (that is, when the motorcycle has not been ridden more than a mile during the past 3 hours).*

144 MAINTENANCE AND ADJUSTMENT

- *Tire pressure is affected by changes in ambient temperature and altitude, and so the tire pressure should be checked and adjusted when your riding involves wide variations in temperature or altitude.*

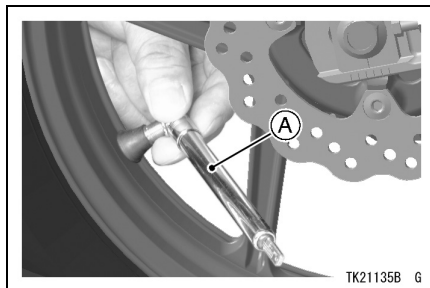

A. Tire Pressure Gauge

Tire Air Pressure (when cold)

Front	225 kPa (2.25 kgf/cm ² , 32 psi)
Rear	250 kPa (2.50 kgf/cm ² , 36 psi)

Tire Wear, Damage

As the tire tread wears down, the tire becomes more susceptible to puncture and failure. An accepted estimate is that 90% of all tire failures occur during the last 10% of tread life (90 % worn). So it is false economy and unsafe to use the tires until they are bald.

- In accordance with the Periodic Maintenance Chart, measure the depth of the tread with a depth gauge, and replace any tire that has worn down to the minimum allowable tread depth.

Minimum Tread Depth

Front	————	1 mm (0.04 in.)
Rear	Up to 130 km/h (80 mph)	2 mm (0.08 in.)
	Over 130 km/h (80 mph)	3 mm (0.12 in.)

MAINTENANCE AND ADJUSTMENT 145

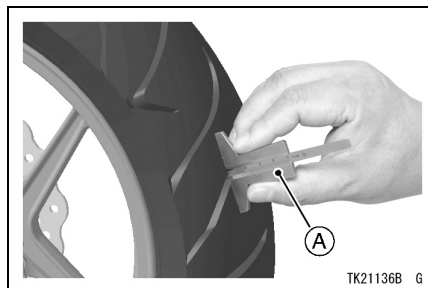

A. Tire Depth Gauge

- Visually inspect the tire for cracks and cuts, replacing the tire in case of

bad damage. Swelling or high spots indicate internal damage, requiring tire replacement.

- Remove any imbedded stones or other foreign particles from the tread.

NOTE

- *Most countries may have their own regulations requiring a minimum tire tread depth; be sure to follow them.*
- *Have the wheel balance inspected whenever a new tire is installed.*

146 MAINTENANCE AND ADJUSTMENT

⚠ WARNING

Tires that have been punctured and repaired do not have the same capabilities as undamaged tires and can suddenly fail, causing an accident resulting in serious injury or death. Replace damaged tires as soon as possible. To ensure safe handling and stability, use only the recommended standard tires for replacement, inflated to the standard pressure. If it is necessary to ride on a repaired tire, do not exceed 100 km/h (60 mph) until the tire is replaced.

Standard Tire (Tubeless)

Front	Size: 120/70ZR17 M/C (58W) DUNLOP ROADSMART II J
Rear	Size: 160/60ZR17 M/C (69W) DUNLOP ROADSMART II J

⚠ WARNING

Mixing tire brands and types can adversely affect handling and cause an accident resulting in injury or death. Always use the same manufacturer's tires on both front and rear wheels.

NOTE

- When operating on public roadways, keep maximum speed under traffic law limits.

⚠ WARNING

New tires are slippery and may cause loss of control and injury. A break-in period of 160 km (100 miles) is necessary to establish normal tire traction. During break-in, avoid sudden and maximum braking and acceleration, and hard cornering.

Battery

The battery installed in this motorcycle is a sealed type, so it is not necessary to check the battery electrolyte level or add distilled water.

The sealing strip should not be pulled off once the specified electrolyte has been installed in the battery for initial service.

However, in order to maximize battery life and ensure that it will provide the power needed to start the motorcycle you must properly maintain the battery's charge. When used regularly, the charging system in the motorcycle helps keep the battery fully charged. If your motorcycle is only used occasionally or for short periods of time, the battery is more likely to discharge.

Due to their internal composition, batteries continually self discharge. The discharge rate depends on the

148 MAINTENANCE AND ADJUSTMENT

type of battery and ambient temperature. As temperature rises, so does the discharge rate. Every 15°C (27°F) doubles the rate.

Electrical accessories, such as digital clocks and computer memory, also draw current from the battery even when the key is switched off. Due to a combination of such "key-off" draws and hot temperature, a battery can go from fully charged to completely discharged in a matter of days.

Self-discharge		
Temperature	Approx. Number of Days From 100% Charged to 100% discharged	
	Lead -Antimony	Lead -Calcium
	Battery	Battery
40°C (104°F)	100 Days	300 Days
25°C (77°F)	200 Days	600 Days
0°C (32°F)	550 Days	950 Days

MAINTENANCE AND ADJUSTMENT 149

Current Drain		
Discharging Ampere	Days from 100% charged to 50% Discharged	Days from 100% charged to 100% Discharged
7 mA	60 Days	119 Days
10 mA	42 Days	83 Days
15 mA	28 Days	56 Days
20 mA	21 Days	42 Days
30 mA	14 Days	28 Days

In extremely cold weather the fluid in an inadequately charged battery can easily freeze, which can crack the case and buckle the plates. A fully charged battery can withstand sub-freezing temperature with no damage.

Battery Sulfation

A common cause of battery failure is sulfation.

Sulfation occurs when the battery is left in a discharged condition for an extended time. Sulfate is a normal by product of the chemical reactions within a battery. But when continuous discharge allows the sulfate to crystallize in the cells, the battery plates become permanently damaged and will not hold a charge. Battery failure due to sulfation is not warrantable.

Battery Maintenance

It is the owner's responsibility to keep the battery fully charged. Failure to do so can lead to battery failure and leave you stranded.

If you are riding your vehicle infrequently, inspect the battery voltage weekly using a voltmeter. If it drops below 12.8 volts, the battery should be charged using an appropriate charger (check with an authorized Kawasaki dealer). If you will not be using the

150 MAINTENANCE AND ADJUSTMENT

motorcycle for longer than two weeks, the battery should be charged using an appropriate charger. Do not use an automotive-type quick charger that may overcharge the battery and damage it.

Kawasaki-recommended chargers are:

Battery Mate 150-9
OptiMate 4
Yuasa MB-2040/2060
Christie C10122S

If the above chargers are not available, use equivalent one.

For more details, ask your Kawasaki dealer.

Battery Charging

- Remove the battery from the motorcycle (see Battery Removal).
- Attach the leads from the charger and charge the battery at a rate (amperage × hours) that is indicated on

the battery. If it is not possible to read the rate, charge the battery at an amperage that is about 1/10th of the battery capacity.

- The charger will keep the battery fully charged until you are ready to re-install the battery in the motorcycle (see Battery Installation).

NOTICE

Never remove the sealing strip, or the battery can be damaged. Do not install a conventional battery in this motorcycle, or the electrical system cannot work properly.

NOTE

- *If you charge the sealed battery, never fail to observe the instructions shown in the label on the battery.*

Battery Removal

- Remove the passenger's seat and rider's seat.
- Disconnect the cables from the battery, first from the (-) terminal and then the (+) terminal.
- Remove the bolts and bracket, then take the battery out of the case.
- Clean the battery using a solution of baking soda and water. Be sure that the cable connections are clean.

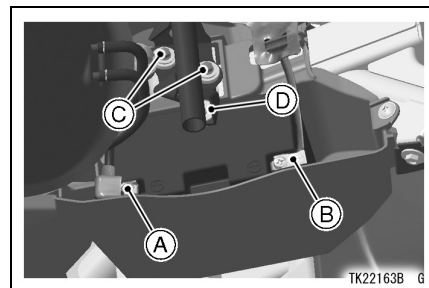

- A. (+) Terminal
- B. (-) Terminal
- C. Bolts
- D. Bracket

Battery Installation

- Place the battery in the battery case.
- Connect the capped cable to the (+) terminal, and then connect the black cable to the (-) terminal.

152 MAINTENANCE AND ADJUSTMENT

NOTE

- *Install the battery in the reverse order of the Battery Removal.*

NOTICE

Installing the (-) cable to the (+) terminal of the battery or the (+) cable to the (-) terminal of the battery can seriously damage the electrical system.

- Put a light coat of grease on the terminals to prevent corrosion.
- Cover the (+) terminal with its protective cap.
- Reinstall the removed parts.

Headlight Beam

Horizontal Adjustment

The headlight beam is adjustable horizontally. If not properly adjusted horizontally, the beam will point to one side rather than straight ahead.

- Turn the horizontal adjuster clockwise or counterclockwise until the beam points straight ahead.

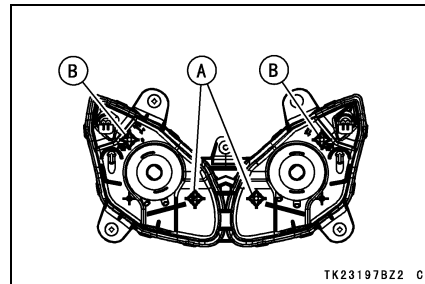

- A. Horizontal Adjuster
- B. Vertical Adjuster

Vertical Adjustment

The headlight beam is adjustable vertically. If adjusted too low, neither low nor high beam will illuminate the road far enough ahead. If adjusted too high, the high beam will fail to illuminate the road close ahead, and the low beam will blind oncoming drivers.

- Turn the vertical adjuster clockwise or counterclockwise to adjust its vertical angle.

NOTE

- *On high beam, the brightest point should be slightly below horizontal with the motorcycle on its wheels and the rider seated. Adjust the headlight to the proper angle according to local regulations.*

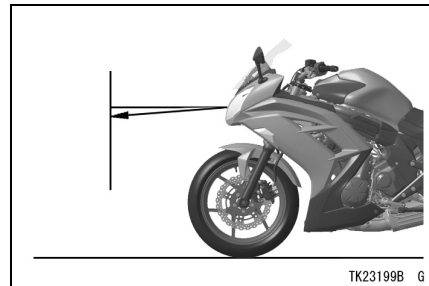

154 MAINTENANCE AND ADJUSTMENT

Fuses

Fuses are arranged in the fuse boxes located under the fuel tank cover and the left frame cover for ABS model. The main fuse is mounted on the starter relay under the rider's seat. If a fuse fails during operation, inspect the electrical system to determine the cause, and then replace it with a new fuse of proper amperage.

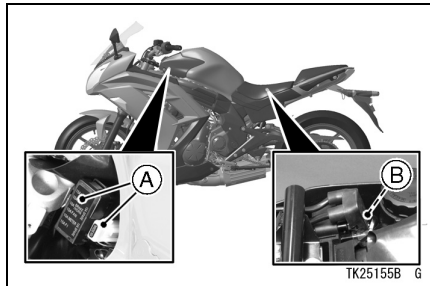

A. Fuse Boxes
B. Main Fuse

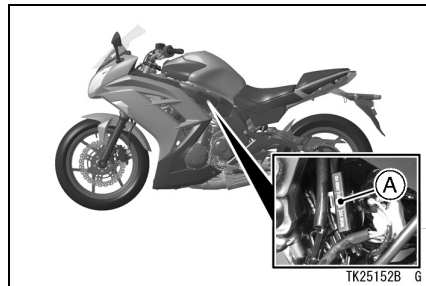

A. Fuse Box (for models equipped with ABS)

⚠ WARNING

Substituting fuses can cause wiring to overheat, catch fire and/or fail. Do not use any substitute for the standard fuse. Replace the blown fuse with a new one of the correct capacity, as specified on the junction box and main fuse.

MAINTENANCE AND ADJUSTMENT 155

- To access the fuse boxes, remove the bolts and slide each side of the tank front cover forwards then pull up the front of the cover to remove it.

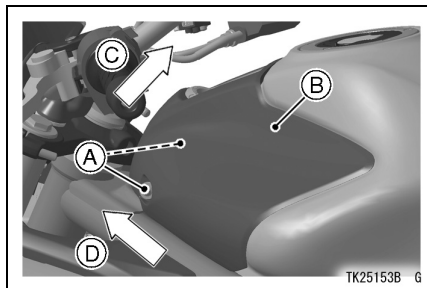

- A. Bolts**
- B. Tank Front Cover**
- C. Pull Up Cover**
- D. Slide Cover Forward**

- To access the fuse box for ABS, remove the left frame side cover by removing the bolt.

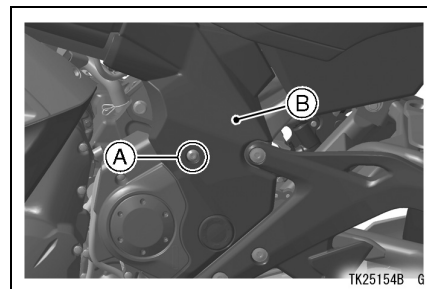

- A. Bolt**
- B. Left Frame Side Cover**

156 MAINTENANCE AND ADJUSTMENT

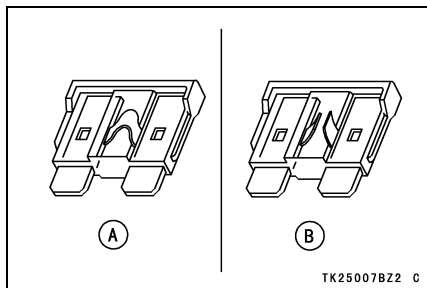

A. Normal
B. Failed

General Lubrication

Lubricate the points shown below, with either motor oil or regular grease, in accordance with the Periodic Maintenance Chart or whenever the vehicle has been operated under wet or rainy conditions.

Before lubricating each part, clean off any rusty spots with rust remover and wipe off any grease, oil, dirt, or grime.

NOTE

○ *A few drops of oil are effective to keep bolts and nuts from rusting and sticking. This makes removal easier. Badly rusted nuts, bolts, etc., should be replaced with new ones.*

Apply engine oil to the following pivots -

- Side Stand
- Clutch Lever
- Front Brake Lever
- Rear Brake Pedal

Lubricate the following cables with a pressure cable lubber -

- (K) Clutch Inner Cable
- (K) Throttle Inner Cables

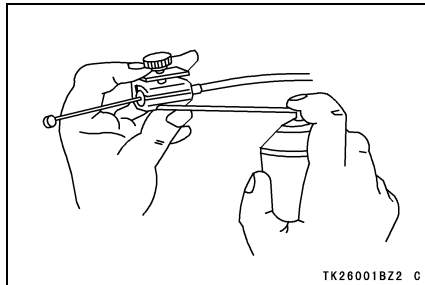

Apply grease to the following points -

- (K) Clutch Inner Cable Upper End
- (K) Throttle Inner Cable Upper Ends

(K): Should be serviced by an authorized Kawasaki dealer.

NOTE

- *After connecting the cables, adjust them.*

158 MAINTENANCE AND ADJUSTMENT

Cleaning Your Motorcycle

General Precautions

Frequent and proper care of your Kawasaki motorcycle will enhance its appearance, optimize overall performance, and extend its useful life. Covering your motorcycle with a high quality, breathable motorcycle cover will help protect its finish from harmful UV rays, pollutants, and reduce the amount of dust reaching its surfaces.

⚠ WARNING

Build-up of debris or flammable material in and around the vehicle chassis, engine, and exhaust can cause mechanical problems and increase the risk of fire.

When operating the vehicle in conditions that allow debris or flammable material to collect in and around the vehicle, inspect the engine, electrical component and exhaust areas frequently. If debris or flammable materials have collected, park the vehicle outside and stop the engine. Allow the engine to cool, then remove any collected debris. Do not park or store the vehicle in an enclosed space prior to inspecting for build-up of debris or flammable materials.

MAINTENANCE AND ADJUSTMENT 159

- Be sure the engine and exhaust are cool before washing.
- Avoid applying degreaser to seals, brake pads, and tires.
- Always use non-abrasive wax and cleaner/polisher.
- Avoid all harsh chemicals, solvents, detergents, and household cleaning products such as ammonia-based window cleaners.
- Gasoline, brake fluid, and coolant will damage the finish of painted and plastic surfaces: wash them off immediately.
- Avoid wire brushes, steel wool, and all other abrasive pads or brushes.
- Use care when washing the windshield, headlight cover, and other plastic parts as they can easily be scratched.
- Avoid using pressure washers; water can penetrate seals and electrical components and damage your motorcycle.
- Avoid spraying water in delicate areas such as in air intakes, fuel system, brake components, electrical components, muffler outlets, and fuel tank openings.

160 MAINTENANCE AND ADJUSTMENT

Washing Your Motorcycle

- Rinse your bike with cold water from a garden hose to remove any loose dirt.
- Mix a mild neutral detergent (designed for motorcycles or automobiles) and water in a bucket. Use a soft cloth or sponge to wash your motorcycle. If needed, use a mild degreaser to remove any oil or grease which build up.
- After washing, rinse your motorcycle thoroughly with clean water to remove any residue (residue from the detergent can damage parts of your motorcycle).
- Use a soft cloth to dry your motorcycle. As you dry, inspect your motorcycle for chips and scratches. Do not let the water air dry as this can damage the painted surfaces.

- Start the engine and let it idle for several minutes. The heat from the engine will help dry moist areas.
- Carefully ride your motorcycle at a slow speed and apply the brakes several times. This helps the brakes dry and restores its normal operating performance.
- Lubricate the drive chain to prevent rusting.

NOTE

- *After riding in an area where the roads are salted or near the ocean, immediately wash your motorcycle with cold water. Do not use warm water as it accelerates the chemical reaction of the salt. After drying, apply a corrosion protection spray on all metal and chrome surfaces to prevent corrosion.*
- *Condensation may form on the inside of the headlight lens after riding in the*

MAINTENANCE AND ADJUSTMENT 161

rain or washing the motorcycle. To remove the moisture, start the engine and turn on the headlight. Gradually the condensation on the inside of the lens will clear off.

Semi-gloss Finish

To clean the semi-gloss finish;

- When washing the motorcycle, always use a mild neutral detergent and water.
- The semi-gloss finish effect may be lost when the finish is excessively rubbed.
- If any doubt, consult an authorized Kawasaki dealer.

Painted Surfaces

After washing your motorcycle, coat painted surfaces, both metal and plastic, with a commercially available motorcycle/automotive wax. Wax should

be applied once every three months or as conditions require. Avoid surfaces with "satin" or "flat" finishes. Always use non-abrasive products and apply them according to the instructions on the container.

Windshield and Other Plastic Parts

After washing use a soft cloth to gently dry plastic parts. When dry, treat the windshield, headlight lens, and other non-painted plastic parts with an approved plastic cleaner/polisher product.

NOTICE

Plastic parts may deteriorate and break if they come in contact with chemical substances or household cleaning products such as gasoline, brake fluid, window cleaners, thread-locking agents, or other harsh chemicals. If a plastic part comes in contact with any harsh chemical substance, wash it off immediately with water and a mild neutral detergent, and then inspect for damage. Avoid using abrasive pads or brushes to clean plastic parts, as they will damage the part's finish.

Chrome and Aluminum

Chrome and uncoated aluminum parts can be treated with a chrome/aluminum polish. Coated aluminum should be washed with a mild neutral detergent and finished with a spray polish. Aluminum wheels, both painted and unpainted can be cleaned with special non-acid based wheel spray cleaners.

Leather, Vinyl, and Rubber

If your motorcycle has leather accessories, special care must be taken. Use a leather cleaner/treatment to clean and care for leather accessories. Washing leather parts with detergent and water will damage them, shortening their life.

Vinyl parts should be washed with the rest of the motorcycle, then treated with a vinyl treatment.

The sidewalls of tires and other rubber components should be treated with a rubber protectant to help prolong their useful life.

 **WARNING**

Rubber protectants can be slippery and, if used on the tread area, cause loss of traction resulting in accident causing injury or death. Do not apply rubber protectant to any tread area.



STORAGE

Preparation for Storage:

- Clean the entire vehicle thoroughly.
- Run the engine for about five minutes to warm the oil, shut it off, and drain the engine oil.

⚠ WARNING

Engine oil is a toxic substance. Dispose of used oil properly. Contact your local authorities for approved disposal methods or possible recycling.

- Put in fresh engine oil.
- Empty the fuel from the fuel tank by the pump or siphon.

⚠ WARNING

Gasoline is extremely flammable and can be explosive under certain conditions, creating the potential for serious burns. Turn the ignition key to "OFF". Do not smoke. Make sure the area is well-ventilated and free from any source of flame or sparks; this includes any appliance with a pilot light. Gasoline is a toxic substance. Dispose of gasoline properly. Contact your local authorities for approved disposal methods.

- Empty the fuel system by running the engine at idle speed until the engine stalls. (If left in for a long time, the fuel will break down and could clog the fuel system.)
- Reduce tire pressure by about 20%.
- Set the motorcycle on a box or stand so that both wheels are raised off the ground. (If this cannot be done, put boards under the front and rear wheels to keep dampness away from the tire rubber.)
- Spray oil on all unpainted metal surfaces to prevent rusting. Avoid getting oil on rubber parts or in the brakes.
- Lubricate the drive chain and all the cables.
- Remove the battery, and store it where it will not be exposed to direct sunlight, moisture, or freezing temperature. During storage it should be given a slow charge (one ampere or less) about once a month. Keep the battery well charged especially during cold weather.
- Tie plastic bags over the mufflers to prevent moisture from entering.

166 STORAGE

- Put a cover over the motorcycle to keep dust and dirt from accumulating on it.

Preparation after Storage:

- Remove the plastic bags from the mufflers.
 - Install the battery in the motorcycle and charge the battery if necessary.
 - Fill the fuel tank with fuel.
 - Check all the points listed in the Daily Safety Checks section.
 - Lubricate the points listed in the General Lubrication section.
- 

ENVIRONMENTAL PROTECTION

To help preserve the environment, properly discard used batteries, tires, oils and fluids, or other vehicle components that you might dispose of in the future. Consult your authorized Kawasaki dealer or local environmental waste agency for their proper disposal procedure. This also applies to disposal of the entire vehicle at the end of its life.

OWNER SATISFACTION

(For Products Sold in Australia Only)

Your satisfaction is important to your authorized Kawasaki dealer and to Kawasaki Motors Pty., Ltd. If you have a problem concerning warranty or service, please take the following action:

Contact the owner and/or service manager of your authorized Kawasaki dealer. Fully explain your problem and ask for assistance in resolving the situation. The OWNER of the dealership is an independent business person and is concerned with your satisfaction and your future business. For this reason the owner is in the best position to assist you. Also, all warranty and service matters are handled and resolved through the authorized Kawasaki dealer network.

If you are unsatisfied after working with your Kawasaki dealer and feel you still require further assistance, WRITE to the address below. Please be certain to provide the model, product identification number, mileage or hours of use, accessories, dates that events occurred and what action has been taken by both you and your dealer. Include the name and address of the dealership. To assist us in resolving your inquiry, please include copies of related receipts and any other pertinent information including the names of the dealership personnel with whom you have been working in the resolution of your problem.

OWNER SATISFACTION 169

Upon receipt of your WRITTEN correspondence we will contact the dealership and work with them in resolving your problem.

In order to provide a permanent record, all warranty and service resolutions take place only through WRITTEN correspondence.

Please send your correspondence to:

Customer Relations:
Technical Service Department
KAWASAKI MOTORS Pty., Ltd.
Private Mail Bag 24
RYDALMERER N.S.W. 2116
A.C.N.: 002 840 315

170 LOCATION OF LABELS

LOCATION OF LABELS

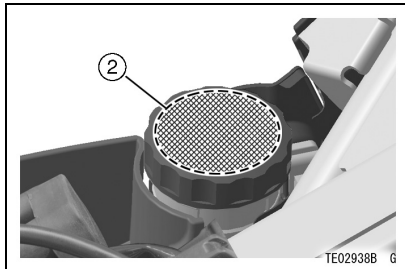
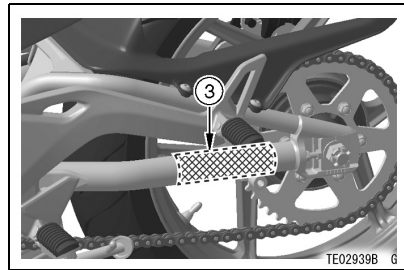
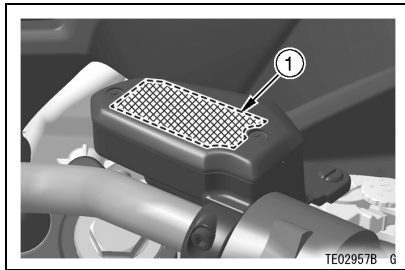

- 1. Brake Fluid (Front)
- 2. Brake Fluid (Rear)
- 3. Important Drive Chain Information

LOCATION OF LABELS 171

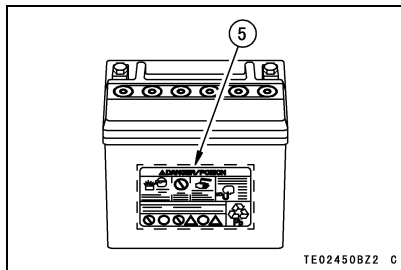
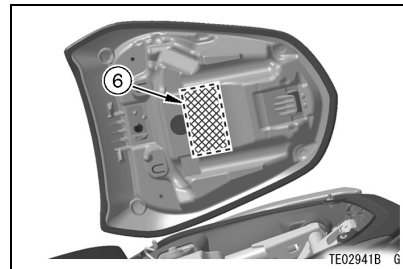
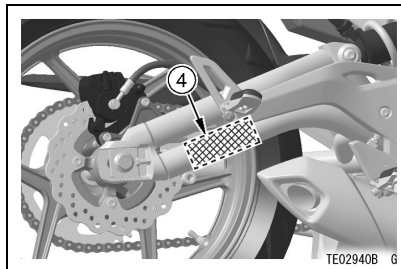

- 4. Tire and Load Data
- 5. Battery Poison/Danger
- 6. Daily Safety Checks

172 LOCATION OF LABELS

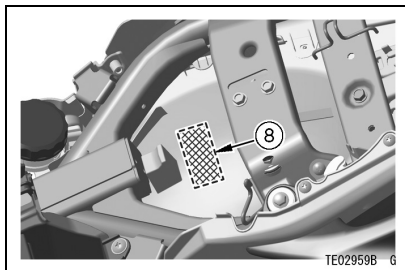
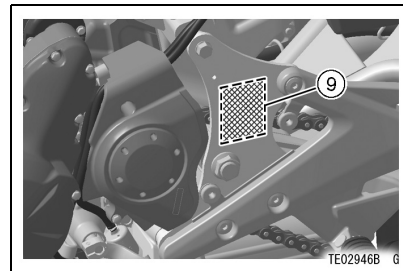
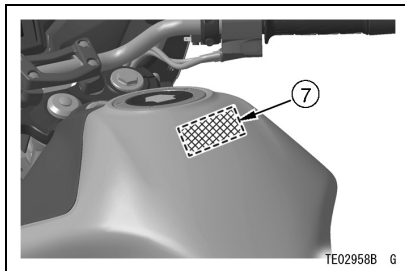

- *7. Fuel Level**
- **8. Stationary Noise Test Information**
- *9. Vacuum Hose Routing Diagram**

- *: Only on Southeast Asia B1 and Thailand models**
- ** : Only on Australian model**

LOCATION OF LABELS 173

(1)



(2)

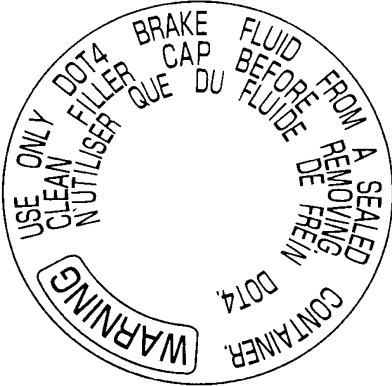

TE03097B S

174 LOCATION OF LABELS

(3)

IMPORTANT DRIVE CHAIN INFORMATION

To prevent an accident and/or damage to the motorcycle, the drive chain must be properly maintained. It should be lubricated every 800km(400mi) and adjusted as often as necessary to keep chain slack at about 25~35mm(1.0~1.4in) measured midway between sprockets on the lower chain run with the motorcycle on the side stand. The standard chain is an DAIDO DID520VP2 with estimated service life of 15000~45000km(9400~28000mi), depending on the severity of use and the frequency of lubrication and adjustment. For safety, replace the chain with only the standard chain any time it wears to over 323mm(12.7in), measured over a 20-link portion pulled straight with 98N(10kgf, 20lbf) of tension. See the Owner's Manual for chain information.

56033-0252 TE03107DN8 C

(4)

TIRE AND LOAD DATA





The stability and handling characteristics of this motorcycle could become unsafe by the use of improper tire inflation pressures, worn tires, unsuitable replacement tires, or overloading. When tire tread wears down to the limit, replace the tire with only the standard tire. Maintain the inflation pressure specified.

	Air Pressure(Cold)	Size & Make Type (Tubeless Tire)	Minimum Tread Depth
Front	Up to 200kg Load (411lbs) 225 kPa (2.25kg/cm ² , 32psi)	DUNLOP 130/70ZR17M/C(58W) ROADSMART # J	1 mm (0.04 in)
Rear	Up to 200kg Load (411lbs) 250 kPa (2.50kg/cm ² , 36psi)	DUNLOP 160/60ZR17M/C(68W) ROADSMART # J	Up to 130 km/h (80MPH) 2 mm (0.08 in) Over 130 km/h (80MPH) 3 mm (0.12 in)







TE03108DN8 C

(5)

⚠ DANGER/POISON

 SHIELD EYES EXPLOSIVE GASES CAN CAUSE BLINDNESS OR INJURY	 NO • SPARKS • FLAMES • SMOKING	 SULFURIC ACID CAN CAUSE BLINDNESS OR SEVERE BURNS	FLUSH EYES IMMEDIATELY WITH WATER  GET MEDICAL HELP FAST
--	---	--	--

KEEP OUT OF THE REACH OF CHILDREN.

IN U.S.A., DISTR. BY
KAWASAKI MOTORS CORP., USA
P.O. BOX 25252
SANTA ANA, CA. 92799-5252

LEAD RETURN
RECYCLE

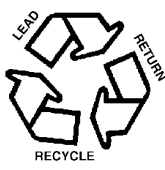
CSG

176 LOCATION OF LABELS

(6)

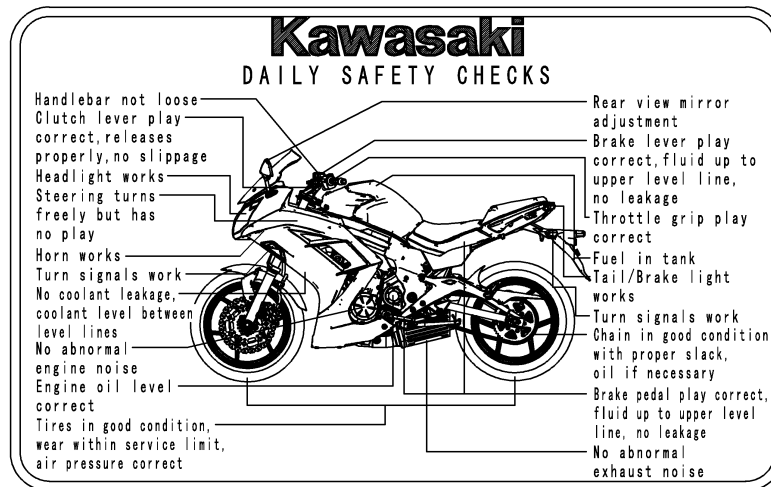

56033-0709

TE03146D29 C

LOCATION OF LABELS 177

(7) only on Southeast Asia B1 and Thailand models



56071-0158
TE03142C S

(8) only on Australian model

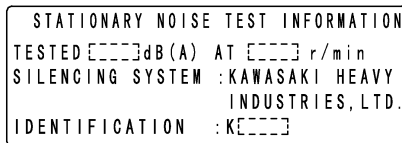

TE03122DN9 C

(9) only on Southeast Asia B1 and Thailand models

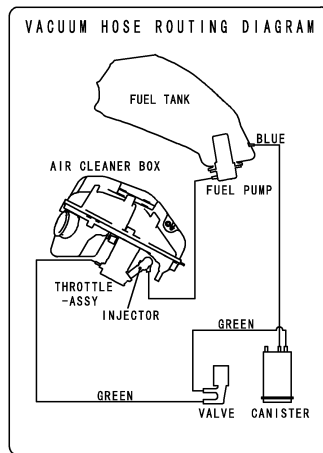

59465-0562

TE03113DN7 C